



A Guide to Local Services IN NARCOTICS ANONYMOUS



Twelve Steps of Narcotics Anonymous

1. We admitted that we were powerless over our addiction, that our lives had become unmanageable.
2. We came to believe that a Power greater than ourselves could restore us to sanity.
3. We made a decision to turn our will and our lives over to the care of God *as we understood Him*.
4. We made a searching and fearless moral inventory of ourselves.
5. We admitted to God, to ourselves, and to another human being the exact nature of our wrongs.
6. We were entirely ready to have God remove all these defects of character.
7. We humbly asked Him to remove our shortcomings.
8. We made a list of all persons we had harmed, and became willing to make amends to them all.
9. We made direct amends to such people wherever possible, except when to do so would injure them or others.
10. We continued to take personal inventory and when we were wrong promptly admitted it.
11. We sought through prayer and meditation to improve our conscious contact with God *as we understood Him*, praying only for knowledge of His will for us and the power to carry that out.
12. Having had a spiritual awakening as a result of these steps, we tried to carry this message to addicts, and to practice these principles in all our affairs.

A Guide to Local Services IN NARCOTICS ANONYMOUS

World Service Office, Inc.
PO Box 9999
Van Nuys, CA 91409-9099 USA

A Guide to Local Services in Narcotics Anonymous

World Service Office, Inc.
PO Box 9999
Van Nuys CA, 91409 USA

Copyright © 1989, 1990, 1991, 1993, 1995, 1996 by World Service Office, Inc.
All rights reserved. Published in the USA.

World Service Office—EUROPE
48 Rue de l'Eté
B-1050 Brussels, Belgium
Tel. +32/2/646-6012
Fax +32/2/649-9239

World Service Office—CANADA
150 Britannia Rd. E. Unit 21
Mississauga, Ontario, L4Z 2A4, Canada
Tel. (905) 507-0100
Fax (905) 507-0101

Twelve Steps and Twelve Traditions adapted and reprinted by permission of Alcoholics Anonymous World Services, Inc.

Twelve Concepts for NA Service is also published separately as a booklet available from World Service Office, Inc. *Twelve Concepts for NA Service* copyright © 1989, 1990, 1991 by World Service Office, Inc. All rights reserved. The *Twelve Concepts for NA Service* were modeled on AA's *Twelve Concepts for World Service*, published by Alcoholics Anonymous World Services, Inc., and have evolved specific to the needs of Narcotics Anonymous.

The chapter in this guide entitled "The NA Group" is also published separately as *The Group Booklet*, copyright © 1990, 1997 by World Service Office, Inc. All rights reserved.



This is NA Conference-approved literature.

**Narcotics
Anonymous®**



The name "Narcotics Anonymous," the stylized initials "NA" alone or within a double circle, and the four-sided diamond enclosed in a circle are registered trademarks and service marks of World Service Office, Inc.

"The NA Way" is a registered trademark of World Service Office, Inc., for its periodical publication.

ISBN 1-55776-246-5. Item no. EN-2111.

GENERAL TABLE OF CONTENTS

Diagram of the NA service structure	v
Detail table of contents	vii
Introduction.....	ix
Twelve Concepts	1
The concepts, created to complement NA's Twelve Traditions, provide specific guidance for the NA service structure described in this guidebook. The primacy of the NA groups is balanced by the necessary delegation of service authority to the service structure; the importance of leadership is balanced by communication and accountability; our belief in group conscience is balanced by NA's respect for the individual. Together, the Twelve Concepts serve as a reminder that "our structure should always be one of service, never of government."	
Developing NA communities	22
This chapter gives a quick overview of how NA services develop in a state, province, or country, starting with the first NA group and developing all the way up to the region. The basic question it addresses is this: How does a developing NA community begin establishing the services which help carry our message to any addict seeking recovery?	
The NA group.....	26
NA groups are local, informal associations of recovering addicts. They are the foundation of the NA service structure. Groups are formed for the primary purpose of carrying the NA message of recovery, and all their activities should reflect that purpose. Conducting Narcotics Anonymous meetings is the primary activity of an NA group. The group may conduct its own affairs in whatever way seems fit to its members, provided the group's actions are consistent with NA's Twelve Traditions and do not adversely affect other groups or the entire NA Fellowship. In the conduct of the affairs of NA as a whole, the groups delegate to the rest of the service structure the responsibility for the fulfillment of NA services. Group service representatives (GSRs) are elected to participate on behalf of the groups in the area committee and the regional assembly.	
The area service committee.....	47
The area committee is the primary means by which the services of a local NA community are administered. The area committee is composed of group service representatives, administrative officers (chairperson, vice chairperson, secretary, treasurer), subcommittee chairpersons, and the area's regional committee members. The area committee elects its own officers, subcommittee chairpersons, and RCMs.	
Dividing area service committees.....	73
Areas grow and change and sometimes need to divide in order to provide NA services effectively. But when? And how? Those are the questions this chapter answers.	

The metropolitan services committee	81
An MSC administers a single set of coordinated NA subcommittees in a city that has more than one ASC, eliminating duplication of services and providing greater effectiveness in carrying the NA message. With direct services consolidated citywide by the metro committee, the community's area committees are left free to facilitate group support.	
The regional service committee	90
The regional committee exists to pool the experience and resources of the areas and groups it serves. The RSC is composed of regional committee members elected by the region's member-areas; these RCMs elect regional committee officers from among themselves. RSCs organize assemblies at which group service representatives and regional committee members discuss a wide range of service matters, including those likely to come before the World Service Conference. The region's delegate to the world conference is elected by the GSRs and RCMs at the regional assembly.	
Local service centers	105
Local NA service centers--sometimes called regional or area service offices, sometimes central offices--provide the NA community with a physical presence and a public identity, a specific point at which Narcotics Anonymous and the larger community can interact with one another. Many serve as local NA literature sales centers. An NA community considering the possibility of opening a local service center will encounter a number of challenges, addressed briefly in this chapter.	
Sample rules of order.....	107
Glossary	115
Index	118
Listing of bulletins, handbooks, and other service-related materials available from the World Service Office	120

NA SERVICE STRUCTURE

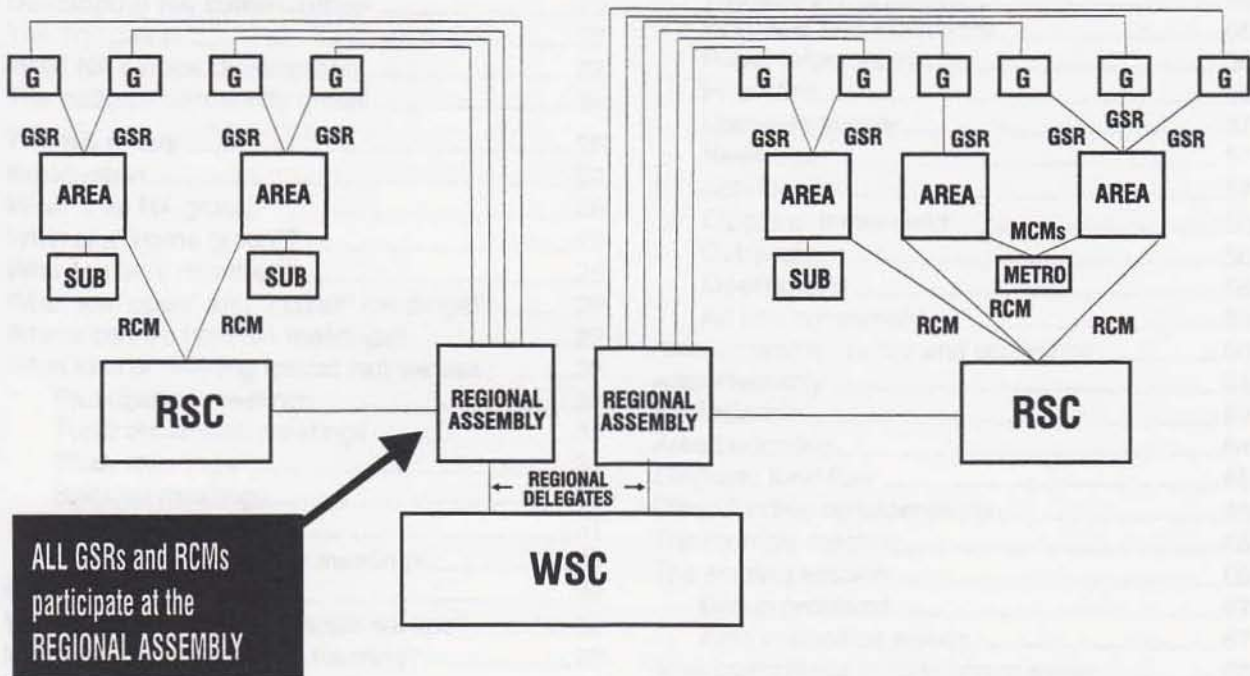

DETAIL TABLE OF CONTENTS

<p>Introduction ix</p> <p>Twelve Concepts for NA Service 1</p> <p>First Concept.....2</p> <p>Second Concept.....3</p> <p>Third Concept.....4</p> <p>Fourth Concept.....6</p> <p>Fifth Concept.....8</p> <p>Sixth Concept.....9</p> <p>Seventh Concept.....11</p> <p>Eighth Concept.....12</p> <p>Ninth Concept.....14</p> <p>Tenth Concept.....16</p> <p>Eleventh Concept.....17</p> <p>Twelfth Concept.....20</p> <p><i>Diagram: NA service structure</i> 21</p> <p>Developing NA communities 22</p> <p>The first group 22</p> <p>Initial NA service development.....22</p> <p>The national community grows 24</p> <p>The NA group.....26</p> <p>Introduction.....26</p> <p>What is an NA group?26</p> <p>What is a "home group"?28</p> <p>Who can be a member?28</p> <p>What are "open" and "closed" meetings?29</p> <p>Where can we hold NA meetings?29</p> <p>What kind of meeting format can we use?30</p> <p style="padding-left: 20px;">Participation meetings31</p> <p style="padding-left: 20px;">Topic discussion meetings31</p> <p style="padding-left: 20px;">Study meetings31</p> <p style="padding-left: 20px;">Speaker meetings.....31</p> <p style="padding-left: 20px;">Newcomer meetings.....31</p> <p style="padding-left: 20px;">Question-and-answer meetings.....31</p> <p>Developing your format32</p> <p>What kinds of literature should we use?32</p> <p>What is a group business meeting?32</p> <p>How does the work get done?33</p> <p>How do we choose group officers?34</p> <p>What officers does a group need?35</p> <p style="padding-left: 20px;">Secretary.....35</p> <p style="padding-left: 20px;">Treasurer35</p> <p style="padding-left: 20px;">Group service representative (GSR).....36</p> <p style="padding-left: 20px;">Alternate GSR.....37</p> <p>Rotation and continuity.....37</p> <p>Group responsibilities.....38</p> <p>Group support for other NA services38</p> <p><i>Diagram: fund flow</i>39</p> <p>Serving our community39</p> <p>How can our group solve its problems?40</p> <p>Sample meeting format42</p> <p>New group checklist45</p> <p>New group registration form.....46</p>	<p>Group update form 46</p> <p>The area service committee 47</p> <p>Introduction.....47</p> <p>The area committee and other NA services..... 48</p> <p>Area committee participants.....48</p> <p>Group service representatives (GSRs)49</p> <p>Administrative officers49</p> <p style="padding-left: 20px;">Chairperson50</p> <p style="padding-left: 20px;">Vice chairperson50</p> <p style="padding-left: 20px;">Secretary.....50</p> <p style="padding-left: 20px;">Treasurer51</p> <p style="padding-left: 20px;">Regional committee members (RCMs)52</p> <p>Elections and rotation.....53</p> <p>Subcommittees.....53</p> <p><i>Diagram: area committee, subcommittees</i>54</p> <p style="padding-left: 20px;">Translation55</p> <p style="padding-left: 20px;">Hospitals and institutions.....55</p> <p style="padding-left: 20px;">Public information56</p> <p style="padding-left: 20px;">Phoneline56</p> <p style="padding-left: 20px;">Literature supply57</p> <p style="padding-left: 20px;">Newsletter57</p> <p style="padding-left: 20px;">Activities.....57</p> <p style="padding-left: 20px;"><i>Diagram: trademarks</i>58</p> <p style="padding-left: 20px;">Outreach58</p> <p style="padding-left: 20px;">Meeting lists.....58</p> <p style="padding-left: 20px;">Ad hoc committees59</p> <p>Area committee policy and guidelines60</p> <p>Area inventory61</p> <p>Participation.....62</p> <p>Area budgeting64</p> <p><i>Diagram: fund flow</i>65</p> <p>Other funding considerations65</p> <p>The monthly meeting.....66</p> <p>The sharing session66</p> <p style="padding-left: 20px;">Group problems67</p> <p style="padding-left: 20px;">Area committee issues67</p> <p>Area committees in rural communities.....68</p> <p><i>Diagram: rural area configuration</i>69</p> <p>Learning days, workshops69</p> <p>Creating new area committees70</p> <p>Sample ASC agenda.....72</p> <p>Dividing area service committees73</p> <p>How to divide74</p> <p style="padding-left: 20px;">Area boundaries74</p> <p style="padding-left: 20px;">Functional analysis75</p> <p>To metro76</p> <p>Or not to metro?76</p> <p><i>Diagram: area shared services</i>77</p> <p>Function, not form78</p> <p>Multiple areas78</p> <p>Why not a metro region?79</p>
--	---

The metropolitan services committee	81	Local service centers	105
Why consolidate?	81	Sample rules of order	107
Consolidation process	82	Decorum statement.....	107
Inventory of services and resources.....	83	Debate, limits.....	107
Analysis of service needs	83	Motions.....	107
The metro plan.....	84	Main motions	108
New focus for ASCs.....	85	Parliamentary motions	108
Fellowship review	85	1. Amend.....	108
Process reminders.....	85	2. Previous question	109
ASCs in the metro environment	85	3. Table	109
ASC responsibilities.....	86	4. Remove from the table	110
Communications	86	5. Refer	110
ASC participants	86	6. Reconsider or rescind.....	110
ASC funding needs.....	87	7. Withdraw a motion	111
<i>Diagram: fund flow</i>	88	8. Substitute motion	111
Metro committee organization.....	88	9. Adjourn.....	111
Area divisions in cities served by an MSC.....	89	Other procedures	111
<i>Diagram: configuring local services with MSC</i>	89	Order of the day	111
The regional service committee	90	Point of information.....	112
Introduction.....	90	Point of order	112
Regional committee participants	90	Point of appeal.....	112
Regional committee members (RCMs)	90	Parliamentary inquiry	112
Regional delegate	91	Point of personal privilege	113
Alternate delegate.....	91	Voting procedures	113
Additional members	92	Motion table.....	114
Resource assignments.....	92	Glossary	115
<i>Diagram: RSC with no subcommittees</i>	93	Index	118
Regional committee meetings.....	93	Bulletins, handbooks, service materials	120
Service forums	94		
Regional assembly.....	96		
Regional delegate elections	96		
Regional finances.....	98		
<i>Diagram: fund flow</i>	98		
Regional activities	99		
Variations on the basic regional model	100		
Regional subcommittees.....	100		
<i>Diagram: RSC with subcommittees</i>	100		
Sharing-format subcommittees.....	101		
Direct service subcommittees.....	101		
<i>Diagram: area shared services</i>	102		
Additional regional assemblies.....	103		
Interregional cooperation	103		
<i>Diagram: regional shared services</i>	104		

INTRODUCTION

There is only one requirement for NA membership, "a desire to stop using," but there are many benefits. One of these benefits is the privilege of service.

We who have the disease of addiction spent years of our lives locked up in ourselves. We were cut off from the warmth and fellowship of other human beings; our lives revolved almost exclusively around "getting and using and finding ways and means to get more." The love that connects one person to another to the next, the selfless service that feeds and houses and clothes and warms and nurtures humankind--of that love, of that selfless service we had no part. That's why it's such a privilege in our recovery to be able to serve others, for we come to know ourselves only in looking beyond ourselves and we keep what we have only by giving it away. By empathizing with other members, by learning to appreciate their needs, by placing them ahead of our own--by these things we learn to love others, and in so doing we learn to love ourselves.

The service we do in our recovery is many things. We take a more active role in our everyday lives, serving others as better friends, better family members, better workers, and better citizens. When we find an NA meeting where we feel at home and NA friends with whom we identify, we've found a home group, a base for our own recovery and a place where we can serve other addicts by sharing our recovery with them. The time, the experience, the empathy we offer others in our home group we extend even further to those we serve in NA sponsorship. All these ways of serving others demonstrate the spiritual awakening of our Twelfth Step, evidenced in our efforts "to carry this message to addicts and to practice these principles in all our affairs." This guidebook describes additional ways recovering addicts can be of service in Narcotics Anonymous. Our hope is that *A Guide to Local Services* will serve as a portal to new paths of service for many, many NA members.

A Guide to Local Services in Narcotics Anonymous is intended to serve as a resource to those in every country who have committed themselves to providing the services necessary to carry our message to the still-suffering addict. Portions of it may prove to be inappropriate for your use either because of geography, national or provincial law, cultural differences, or the developmental state of your NA community. If this is the case, your NA community should feel free to adapt the *Guide* to meet your own needs, provided that those adaptations are consistent with NA's Twelve Steps, Twelve Traditions, and Twelve Concepts for Service. For further information concerning local adaptation of material from *A Guide to Local Services*, contact NA's World Service Office.

NOTE

The first chapter of this guide, "Twelve Concepts for NA Service," was approved in its entirety by NA's World Service Conference in 1992.

It is also published separately as a booklet that can be purchased from our World Service Office.

The booklet has a special study section for individuals and groups.

TWELVE CONCEPTS FOR NA SERVICE

The Twelve Traditions of NA have guided our groups well in the conduct of their individual affairs, and they are the foundation for NA services. They have steered us away from many pitfalls that could have meant our collapse. Our various service units *serve*, for example, they do not govern; we stay out of public debate; we neither endorse nor oppose any of the many causes that our members may feel strongly about; our approach to addiction is a nonprofessional one; we are fully self-supporting. The traditions have provided our fellowship with essential guidance throughout its development, and they continue to be indispensable.

The Twelve Concepts for NA Service described here are intended to be practically applied to our service structure at every level. The spiritual ideals of our steps and traditions provide the basis for these concepts, which are tailored to the specific needs of our fellowship's service structure. The concepts encourage our groups to more readily achieve our traditions' ideals, and our service structure to function effectively and responsibly.

These concepts have been crafted from our experience. They are not intended to be taken as the "law" for NA service, but simply as guiding principles. We find that our services are stabilized when we conscientiously apply these concepts, much as our steps have stabilized our lives and our traditions have stabilized and unified our groups. The Twelve Concepts guide our services and help ensure that the message of Narcotics Anonymous is available to all addicts who have a desire to stop using and begin practicing our way of life.

1. To fulfill our fellowship's primary purpose, the NA groups have joined together to create a structure which develops, coordinates, and maintains services on behalf of NA as a whole.
2. The final responsibility and authority for NA services rests with the NA groups.
3. The NA groups delegate to the service structure the authority necessary to fulfill the responsibilities assigned to it.
4. Effective leadership is highly valued in Narcotics Anonymous. Leadership qualities should be carefully considered when selecting trusted servants.
5. For each responsibility assigned to the service structure, a single point of decision and accountability should be clearly defined.
6. Group conscience is the spiritual means by which we invite a loving God to influence our decisions.
7. All members of a service body bear substantial responsibility for that body's decisions and should be allowed to fully participate in its decision-making processes.

8. Our service structure depends on the integrity and effectiveness of our communications.
9. All elements of our service structure have the responsibility to carefully consider all viewpoints in their decision-making processes.
10. Any member of a service body can petition that body for the redress of a personal grievance, without fear of reprisal.
11. NA funds are to be used to further our primary purpose, and must be managed responsibly.
12. In keeping with the spiritual nature of Narcotics Anonymous, our structure should always be one of service, never of government.

FIRST CONCEPT

To fulfill our fellowship's primary purpose, the NA groups have joined together to create a structure which develops, coordinates, and maintains services on behalf of NA as a whole.

Our fellowship's primary purpose is to carry the message "that an addict, any addict, can stop using drugs, lose the desire to use, and find a new way to live." One of the primary means by which that message is carried, addict to addict, is in our meetings. These recovery meetings, conducted thousands of times each day by NA groups around the world, are the most important service offered by our fellowship.

However, while recovery meetings are NA's most important service, they are not the only means we have of fulfilling our fellowship's primary purpose. Other NA services attract the still-suffering addict to our meetings, carry our message to addicts in institutions, make recovery literature available, and provide opportunities for groups to share their experience with one other. No one of these services, by itself, comes close to matching the value of group recovery meetings in carrying our message; each, however, plays its own indispensable part in the overall program devised by the NA Fellowship to fulfill its primary purpose.

We can do together what we cannot accomplish separately. This is true in our personal recovery and is equally true in our services. In new NA communities, groups often perform basic services in addition to their meetings. But fulfillment of the full range of NA services--phonelines, H&I panels, public information work, outreach, and the rest--usually requires more people and more money than a single group can muster on its own. The degree of organization necessary to carry out such responsibilities would divert most groups from carrying the NA message in their meetings. And the lack of coordination among groups delivering various services on their own could result in duplication,

confusion, and wasted resources. For these reasons, most groups do not take such responsibilities on themselves.

How, then, can NA's groups ensure the fulfillment of these services? They do so by combining their resources, joining together to create a structure which develops, coordinates, and maintains those services for them, leaving the groups free to carry out their own primary responsibility.

SECOND CONCEPT

The final responsibility and authority for NA services rests with the NA groups.

The NA service structure has been created by the groups to serve the common needs of the groups. Our fellowship's service boards and committees exist to help groups share their experience with one another, provide tools which help groups function better, attract new members to group recovery meetings, and carry the NA message further than any single group could carry it alone. Because the groups have created the service structure, they have final authority over all its affairs. By the same token, the groups also have the final responsibility for the support of all its activities. The two go hand in hand.

Ideally, responsibility and authority are flip sides of the same coin; the exercise of one is also an exercise of the other. When our groups provide the resources--conscience and ideas, people, money--needed to fulfill NA services, they also provide direction to the service structure. Let's take a look at a few examples of how this principle works.

The most important resource contributed to the service structure by an NA group is almost exclusively spiritual: its ideas and its conscience. Without the voice of the groups, the service structure may not know what kinds of services are needed, or whether the services it provides are ones the groups want. The groups provide the ideas and direction needed to guide the service structure in fulfilling its responsibilities. By voicing their needs and concerns, the groups also exercise their authority for the service structure they have created.

The people who give their time to service work are a vital resource; without them, our service boards and committees would not exist, much less be able to serve. The group's responsibility to the service structure is to elect a group service representative who will serve the best interests of the group and the entire NA Fellowship. By carefully selecting its GSR, then providing that person with regular support and guidance, the group exercises its ability to impact NA services, both directly and indirectly. In choosing a qualified GSR, then sending him or her out to serve on the group's behalf, the group fulfills a large part of both its responsibility and authority for NA services.

Money is required to fulfill NA services. Without it, our phonedlines would be closed down, our meeting lists would not be printed, there would be no NA literature to distribute, our H&I panels would go without pamphlets, and our public information workers would be unable to provide printed materials about our fellowship to the community. In the Eleventh Concept, more will be said of the use of money in fulfilling our primary purpose. The message of the Second Concept in regard to money, however, is simple: Since the groups have created the service structure to perform certain tasks, the groups are also responsible to provide the necessary funds.

So far, we've looked at what the Second Concept says to the NA group. This concept also speaks to the service structure. The groups have, directly or indirectly, created every one of our service boards and committees. The NA groups have, directly or indirectly, provided the resources used by those service boards and committees. The groups have established the service structure as a medium through which, together, they can better fulfill our fellowship's primary purpose. Therefore, in all the affairs of all its elements, the service structure must carefully consider the needs and desires of the groups. The Second Concept can be seen as the groups' way of saying to the NA service structure, "Be responsible with the spiritual, personal, and financial resources we have provided you. Seek our advice; do not ignore our direction."

The NA groups bear the final authority in all our fellowship's service affairs and should be routinely consulted in all matters directly affecting them. For example, proposals to change NA's Twelve Steps, Twelve Traditions, name, nature, or purpose should be approved directly by the groups. Conversely, if something goes wrong in the service structure, NA groups are responsible to take constructive steps to help correct the problem. Our experience shows that radical action, taken in haste, serves neither the groups nor our services well. Since change rarely occurs overnight, patience and acceptance may be called for. Nonetheless, the exercise of final authority for NA services, a vital part of the system of service established by our fellowship, is both the right and the responsibility of the groups.

THIRD CONCEPT

The NA groups delegate to the service structure the authority necessary to fulfill the responsibilities assigned to it.

The NA groups maintain final responsibility and authority for the service structure they have created. Yet if they must involve themselves directly in making decisions for all of our service boards and committees, the groups will have little time or energy left to carry the recovery message in their meetings. For this

reason, the groups entrust the service structure with the authority to make necessary decisions in carrying out the tasks assigned to it.

The delegation of authority can do much to free up both our groups and our services. Service decisions not directly affecting the groups can be made expeditiously; our phonedines, H&I panels, public information efforts, and literature development projects can move forward at full speed to serve NA's primary purpose. And our groups, not required to ratify every decision made on their behalf at every level of service, are freed to devote their full attention to carrying the NA message in their meetings.

We often use motions and guidelines to help us apply the Third Concept. We clearly describe each task we want accomplished, and the kind of authority we are delegating to those who will fulfill the task. However, even the most exhaustive set of guidelines cannot account for every eventuality. Our trusted servants will serve us best when we grant them the freedom to exercise their best judgment in fulfilling the responsibilities we've assigned them. Our services must remain directly accountable to those they serve, yet they must also be given a reasonable degree of discretion in fulfilling their duties. A group, service board, or committee should consult its collective conscience in arriving at its own understanding of the best way to apply this concept.

Sometimes we fear that delegation will mean a loss of control over our services. Together, Concepts One, Two, and Three have been designed to help us maintain responsibility for our service structure without tying our trusted servants' hands. The Third Concept encourages our groups to focus on their own responsibilities while assuring that the service structure is given the authority it needs to fulfill other necessary NA services. Our Twelve Concepts do not ask our groups to abdicate their authority, allowing the service structure to do whatever it pleases. The groups, after all, have established the service structure to act on their behalf, at their direction. And when the groups need to exercise final authority in service matters, they are encouraged to do so. However, in day-to-day matters, the groups have given our service boards and committees the practical authority necessary to do the jobs assigned them.

Delegating authority can be a risky business unless we do so responsibly. To make Concept Three work, other concepts must also be applied consistently. Most importantly, we must give careful attention to the selection of trustworthy trusted servants. We cannot responsibly delegate authority either to those who are fundamentally incapable of administering that authority or to those who are not willing to account fully for their actions. However, if we select our leaders carefully, choosing those who can be trusted to responsibly exercise delegated authority in fulfilling the tasks we've given them, we can feel much more comfortable with the concept of delegation.

When we give our trusted servants a job, we must adequately describe to them the job we want done, and we must provide them with the support they need to complete their job. Then, once we've given them instructions and support, we must delegate to them the authority necessary to make decisions related to the task they've been assigned. When our groups delegate sufficient authority to our service structure, our groups need not be overcome with the demands of making every service decision at every level of service, and our fellowship's primary purpose can be served to the fullest. With the Third Concept squarely in place, our groups are free to conduct recovery meetings and carry the NA message directly to the addict who still suffers, confident that the service structure they have created has the authority it needs to make the decisions involved in fulfilling its responsibilities.

FOURTH CONCEPT

Effective leadership is highly valued in Narcotics Anonymous. Leadership qualities should be carefully considered when selecting trusted servants.

The trust necessary to confidently delegate service authority is founded on the careful selection of trusted servants. In the following paragraphs, we highlight a number of the qualities to be considered when choosing our trusted servants. No leader will exemplify all these qualities; they are the ideals of effective leadership to which every trusted servant aspires. The more we consider these qualities when selecting NA leaders, the better our services will be.

Personal background and professional or educational qualifications, though helpful, do not necessarily make for effective leadership. When selecting trusted servants, after all, it is the whole person we trust, not just their skills. And one of the first things we look for when selecting trusted servants is humility. Being asked to lead, to serve, to accept responsibility, is a humbling experience for a recovering addict. Through continuing to work the Twelve Steps, our trusted servants have come to know not only their assets but their defects and their limitations. Knowing that, they have agreed to serve our fellowship to the best of their ability, with God's help. Good NA leaders do not think they have to do everything themselves; they ask for help, advice, and direction on a regular basis. Our fellowship's leaders ought not be dictators or order-givers; they are our servants. Able leadership in the spirit of service does not drive by arrogant mandate, demanding conformity; it leads by example, inviting respect. And nothing invites us to respect our trusted servants more than clear evidence of their humility.

Capable NA leadership exhibits the full range of personal characteristics associated with a spiritual awakening. We depend on those who serve us to report on their activities completely and truthfully. Our leaders must have the

integrity needed to hear others well, yet still be able to stand fast on sound principle; to compromise, and to disagree without being disagreeable; to demonstrate the courage of their convictions, and to surrender. We seek trusted servants who are willing to expend their time and energy in the diligent service of others, studying available resource materials, consulting those with greater experience in their field of responsibility, and carefully fulfilling the tasks we've given them as completely as possible. Honesty, open-mindedness, and willingness, indispensable in recovery, are also essential to leadership.

Any NA member can be a leader, and every NA member has the right to serve the fellowship. Effective NA leadership knows not only how to serve, but when it will serve best to step aside and allow others to take over. An entrenched bureaucracy inhibits our fellowship's growth, while a regular influx of new leadership, balanced by continuity, inspires NA growth. The effective leader also knows that, in order to maintain the distinction in service between principles and personalities, it is important to observe the practice of rotation.

In some positions, trusted servants need specific skills in order to act as effective leaders. The ability to communicate well can help our trusted servants share information and ideas, both in committee work and in reporting to those they serve. Organizational skills help trusted servants keep small service responsibilities simple, and make straightforward even the fulfillment of complex tasks. Leaders capable of discerning where today's actions will take us, and of offering us the guidance we need to prepare for the demands of tomorrow, serve Narcotics Anonymous well. Certain educational, business, personal, and service experiences may suit a recovering addict more to one type of service commitment than another. We do ourselves, our fellowship, and our trusted servants a disservice when we ask our members to perform tasks they are incapable of fulfilling.

When we carefully consider the leadership qualities of those we ask to serve, we can confidently give them the room they need to exercise those qualities on our behalf. We can allow effective leaders freedom to serve, especially when they demonstrate their accountability to us, reporting regularly on their work and asking, when necessary, for additional direction. True, our leaders are but trusted servants, not governors; yet we also expect our trusted servants to lead us. If we select them carefully, we can confidently allow them to do so.

Effective leadership is highly valued in NA, and the Fourth Concept speaks of the qualities we should consider when selecting leaders for ourselves. However, we should remember that the fulfillment of many service responsibilities requires nothing more than the willingness to serve. Other responsibilities, while requiring certain specific skills, depend for their fulfillment far more heavily on the trusted servant's spiritual maturity and personal integrity. Willingness, spiritual depth,

and trustworthiness are strong demonstrations of the kind of leadership valued most highly in Narcotics Anonymous.

We should also remember that NA's leaders are not only those we vote into office. Opportunities for selfless service arise wherever we turn in Narcotics Anonymous. NA members exercise personal leadership by helping clean up after a meeting, taking extra care to welcome newcomers to our fellowship, and in countless other ways. As recovering addicts, any of us can fulfill a leadership role, providing a sound example, by serving our fellowship. This modest spirit of service to others forms the foundation of our Fourth Concept, and of NA leadership itself.

FIFTH CONCEPT

For each responsibility assigned to the service structure, a single point of decision and accountability should be clearly defined.

The key to applying the Fifth Concept is in defining the task that needs to be done, and the easiest way to apply it is right from the start. When we first create a service task, we should consider what kind of authority we must delegate in order for that task to be accomplished and what kind of accountability we should require of those to whom we are giving that task. Then, one particular trusted servant, service board, or committee should be designated as the single point of decision and accountability for that assignment. This simple principle applies to all the services provided in Narcotics Anonymous, from the group to our world services.

When we decide a certain service task should be done and clearly say which trusted servant, service board, or committee has the authority to accomplish the task, we avoid unnecessary confusion. We don't have two committees trying to do the same job, duplicating efforts or squabbling over authority. Project reports come straight from the single point of decision for the project, offering the best information available. An assigned service responsibility can be fulfilled swiftly and directly, because there is no question of whose responsibility it is. And if problems in a project arise, we know exactly where to go in order to correct them. We do well when we clearly specify to whom authority is being given for each service responsibility.

The single point of decision we define for each service responsibility is also a single point of accountability. As we've already seen in the Fourth Concept, and as we shall see further in Concept Eight, accountability is a central feature of the NA way of service. When we give our trusted servants responsibility for a particular service task, we hold them accountable for the authority we've delegated them. We expect them to remain accessible, consistently providing us with reports of their progress and consulting with us about their responsibilities.

Accountability does not mean that we delegate authority only to take it right back. It simply means that we want to be informed of decisions our trusted servants are considering as they go about the tasks we've assigned them. We want to have the opportunity to impact those decisions, especially if they directly affect us. And we want to be kept up-to-date on each responsibility we've assigned to the service structure so that, if something goes wrong, we can take part in making it right.

The Fifth Concept helps us responsibly delegate our authority for NA services. In exercising the Fifth Concept, we make a simple, straightforward contract with our trusted servants. Right from the start, they know what we are asking of them, what decisions they are expected to make themselves, and to what degree we will hold them accountable for the service work they do on our behalf. Exercise of Concept Five is not a task to be taken lightly. It calls for us to carefully consider the service work we want done; to clearly designate who should do that work; to delegate the authority to do it; and to maintain accountability for those duties. It takes effort to conscientiously apply Concept Five, but the results are worth the effort.

SIXTH CONCEPT

Group conscience is the spiritual means by which we invite a loving God to influence our decisions.

Conscience is an essentially spiritual faculty. It is our innate sense of right and wrong, an internal compass that each of us may consult in our personal reflections about the best course to take. Our Basic Text refers to conscience as one of those "higher mental and emotional functions" which was "sharply affected by our use of drugs." By applying our steps, we seek to revive it and learn how to exercise it. As we steadily apply spiritual principles in our lives, our decisions and actions increasingly become less motivated by self-interest and more motivated by what our conscience tells us is good and right.

When addicts whose *individual* consciences have been awakened in the course of working the steps come together to consider service-related questions, either in their NA group or in a service committee meeting, they are prepared to take part in the development of a *group* conscience. The exercise of group conscience is the act by which our members bring the spiritual awakening of our Twelve Steps directly to bear in resolving issues affecting NA. As such, it is a subject which must command our most intent consideration.

The development of a group conscience is an indispensable part of the decision-making process in Narcotics Anonymous; however, group conscience is not itself a decision-making mechanism. To clarify the difference between the two, let's look at our personal lives. People living spiritually oriented lives usually

pray and meditate before making major decisions. First, we look to our source of spiritual strength and wisdom; then, we look forward and chart our course. If we automatically claim that God has guided us every time we make a decision, whether or not we've actually invited God to influence us prior to making that decision, we fool only ourselves. The same applies to group conscience and collective decision-making.

Developing a collective conscience provides us with the spiritual guidance we need for making service decisions. We pray or meditate together, we share with one another, we consider our traditions, and we seek direction from a Higher Power. Our groups, service boards, and committees often use the vote as a rough tool for translating that spiritual guidance into clear, decisive terms. Sometimes, however, no vote is needed; following thoughtful, attentive discussion, it is perfectly apparent what our collective conscience would have us do in a given service situation. Just as we seek the strongest possible spiritual unity in Narcotics Anonymous, so in our decision-making we seek unanimity, not merely a majority vote. The more care we take in our considerations, the more likely we are to arrive at unanimity, and no vote will be needed to help us translate our group conscience into a collective decision.

When making specific service decisions, voting or consensus may be the measure of our group conscience. However, group conscience can be seen in all our fellowship's affairs, not merely in our decision-making process. The group inventory process is a good example of this. When members of an NA group gather together to examine their group's effectiveness in fulfilling its primary purpose, they each consult their own conscience concerning their individual role in the life of the group. They consider the concerns of the group as a whole in the same light. Such a group inventory session might produce no specific service decisions whatsoever. It will, however, produce among group members a heightened spiritual sensitivity both to the needs of the still-suffering addict and to the needs of fellow group members.

Another example of group conscience being developed without producing a service-related decision, one each of us can identify with, can be found every day of the week in our recovery meetings. Many are the times when we go to an NA meeting with a personal problem, seeking comfort, support, and guidance in the experience of other recovering addicts. Our members, each with their individual personalities, backgrounds, and needs, speak to one another--and to us--of the spiritual awakening they've found in applying the Twelve Steps in their lives. From the diversity of the group a common message arises, a message we can apply to our own lives, the message of recovery. In this message we find "the therapeutic value of one addict helping another." We also find in this message

the group conscience, applied not to a service issue but to our own spiritual growth.

Group conscience is the means by which we collectively invite the ongoing guidance of a Higher Power in making decisions. We apply the Sixth Concept when we pursue our own personal recovery with vigor, seeking that ongoing spiritual awakening which makes it possible for us to apply the principles of the program in all our affairs, including our service affairs. We apply the Sixth Concept when we listen not just to the words our fellow members speak but to the spirit behind their words. We apply the Sixth Concept when we seek to do God's will, not our own, and to serve others, not ourselves, in our service decisions. We apply the Sixth Concept in our groups, service boards, and committees when we invite a loving God to influence us before making service-related decisions.

SEVENTH CONCEPT

All members of a service body bear substantial responsibility for that body's decisions and should be allowed to fully participate in its decision-making processes.

The Seventh Concept is one way of putting the principle of group conscience to work in the service environment. This concept suggests that each service body should encourage all its members to participate in its decision-making process. By bringing their different perspectives together, we give our service bodies the opportunity to develop a fully informed, balanced group conscience leading to sound, sensitive service decisions.

Our service boards and committees represent a cross-section of NA perspective and experience. Each participant's contribution to the decision-making process is important. Determining participation at the group level is fairly simple: if you're a group member, you may fully participate in the group's decision-making process. Determining participation in the decision-making processes of most service boards and committees is a little more involved, yet the same basic principles still apply. Freely expressed individual conscience is the essential element in group conscience at any level.

NA service is a team effort. Our service representatives are responsible to the NA Fellowship as a whole rather than any special constituency; so are all the other trusted servants on the team. The full participation of each member of the team is of great value as we seek to express the collective conscience of the whole.

There is no firm rule about how to apply the concept of participation to every situation. In an atmosphere of love, mutual respect, and frank, open discussion, each service body decides these things for itself. In significant matters affecting

the groups, a service body will want to ask for guidance directly from the groups. In the vast majority of cases, however, the service body will exercise its delegated authority in fulfilling the responsibilities the groups have assigned to it, disposing of the matters in the normal course of their service meetings.

NA's principle of spiritual anonymity is the foundation for the Seventh Concept. This principle points our fellowship toward a leveling of the individual's relative importance as a participant in NA service. The Seventh Concept, with its emphasis on equalizing the relative weight of each voice on the team, puts the spiritual principle of anonymity into practice. Though we may not all participate in every decision made in our fellowship, we all have the right to participate fully and equally in the decision-making processes in the service bodies in which we are members.

EIGHTH CONCEPT

Our service structure depends on the integrity and effectiveness of our communications.

Our fellowship's service structure is founded on the unity of our groups; to maintain that union, we must have regular communications throughout Narcotics Anonymous. Together, our groups have created a service structure to meet their common needs and to help them fulfill their common purpose. The effectiveness of the service structure depends on the continued unity of the NA groups, and on their continued support and direction. These things can only be maintained in an atmosphere of honest, open, and straightforward communication among all parties concerned.

Regular communication plays a large part in the fulfillment of our groups' final responsibility and authority for NA services. Through their GSRs, the groups regularly report their strengths, needs, ideas, and conscience to the service structure. Taken together, these group reports give our service boards and committees clear guidance in their efforts to serve NA as a whole. When the groups are regularly given full and accurate information from all elements of the service structure, they become familiar with the structure's normal patterns of activity. The groups are then able to recognize when something goes wrong with one of our service boards and committees and are in a better position to know how to help correct the problem. And, knowing what kinds of resources are needed to fulfill service tasks, our groups are also more likely to provide the service structure with adequate support.

Clear, frequent two-way communication is an important prerequisite for delegation. When our groups ask the service structure to fulfill certain responsibilities on their behalf, we delegate to the structure the authority needed to make decisions related to those responsibilities. We need to be able to trust

NINTH CONCEPT

All elements of our service structure have the responsibility to carefully consider all viewpoints in their decision-making processes.

It's easy to discuss things with those who agree with us. But in recovery we've learned that our own best thinking may not necessarily offer us the best possible guidance. We have been taught that, before making significant decisions, we should check our judgment against the ideas of others. Our experience has shown us that the ideas of those who disagree with us are often the ones we need most to hear. The Ninth Concept puts this aspect of our recovery experience to work in the service environment. When making a decision, our groups, service boards, and committees should actively seek out all available viewpoints.

An effective group conscience is a fully informed group conscience. The Ninth Concept is one tool we use to help ensure that our group conscience is as well-informed as it can possibly be. In any discussion, it is tempting to ignore dissenting members, especially if the vast majority of members think alike. Yet it is often the lone voice, offering new information or a unique perspective on things, that saves us from hasty or misinformed decisions. In Narcotics Anonymous, we are encouraged to respect that lone voice, to protect it, even to seek it out, for without it our service decisions would undoubtedly suffer.

Concept Nine also encourages us, individually, to frankly speak our minds in discussions of service issues, even when most other members think differently. No, this concept is not telling us to become perpetual nay-sayers, objecting to anything agreed to by the majority. It does say, however, that we are responsible to share our thoughts and our conscience with our fellow members, carefully explaining our position and listening with equal care to the positions of others. When we show the courage necessary to speak our mind while also showing respect for one another, we can be confident that we act in the best interests of the NA Fellowship. By insisting on thorough discussion of important issues, the worst we can do is take a little of each other's time; at best, we protect the fellowship from the consequences of a hasty or misinformed decision.

When a service body is in the process of making a decision, the Ninth Concept can be exercised in a variety of ways. If you are a member of that service body, all you need do is raise your hand and speak. If the point you wish to make is complex, you may wish to put it in writing so that other members of the board or committee can study it more carefully.

If you are not a member of the service body in question but, as an NA member, still have something to say about a service matter, there are a variety of avenues you can take to express your position. By sharing your views at your

group's business meeting, you ensure that your ideas will be included in the mix of group conscience that guides your GSR when she or he participates in service discussions. Many service boards or committees set aside a portion of their agenda for open forums when you can speak your own mind on issues before the body. Fellowship newsletters and journals, from the local to the world level, often offer space where NA members can share their viewpoints on service matters at hand. Whether or not you are a member of a service body, there are a variety of ways in which you can personally exercise the Ninth Concept.

Our decision-making process is not perfect. Many groups, service boards, and committees acknowledge this, and the value of the minority's position, with every decision they make. Whenever a motion is approved by something less than unanimous consent, these service bodies often ask those who voted against the measure to state their reasons for doing so, either out loud or in writing. If the decision needs to be revised at a later date, such minority opinions may prove invaluable in helping chart a new service course.

Concept Nine encourages us to continue to consult group conscience, even after a decision has already been made. If discussions are raised about a question already decided, the body is bound to hear those discussions. It may be that, based on such discussion, a service body will alter its earlier decision. However, if a past decision is questioned, discussion is well heard, and the decision still stands, the time comes for everyone to accept that decision and to cooperate wholeheartedly in its implementation. Half-hearted support of or outright resistance to such a decision runs contrary to our principles of surrender and acceptance. Once a decision has been made, reconsidered, and confirmed, we need to respect it and go on about the business of serving our fellowship.

The expression of the individual conscience to the group is the foundation of group conscience. Without it, we block the guidance of a loving God, our ultimate authority. When a position supported by many of us is challenged by a few of us, our service boards and committees should always treat such input with great respect and careful consideration. The information and insights offered by the few may save us from dangerous mistakes; they may even lead us to new, previously undreamt-of horizons of service where we might fulfill our fellowship's primary purpose more effectively than ever. For the sake of our fellowship, and for the sake of our members yet to come, our groups, service boards, and committees must always carefully consider all viewpoints in their decision-making processes.

TENTH CONCEPT

Any member of a service body can petition that body for the redress of a personal grievance, without fear of reprisal.

The Tenth Concept is our fellowship's guarantee of respect for the individual trusted servant. This concept may seem self-evident, but our belief in the principle involved is so strong that we want to say it loudly and clearly. Narcotics Anonymous is a spiritual society, with high ideals for how we treat each other. Our members, however, are only human, and we sometimes mistreat one another. The Tenth Concept is our spiritual society's promise that if one of us is wronged in the service environment, the aggrieved trusted servant may ask that the wrong be made right.

A variety of circumstances may require application of the Tenth Concept. In one case we know of, a member was nominated for office on his area service committee. The member left the room, allowing the committee to discuss his qualifications. During that discussion, certain ASC members groundlessly slandered the candidate's personal reputation; as a result, the member was defeated. This man found out about the discussion of his personal life and its effect on the election a few days later. Feeling hurt and angry, he decided to talk with his sponsor, inventory his own part in the matter, and pray for guidance. After taking these steps, he felt confident that he was entitled to petition the ASC for redress. He wrote a letter stating that he believed he had been wronged by the ASC, asking for a new ballot. The following month, his letter was read and discussed during the committee's sharing session. After having a chance to examine their consciences, the ASC members admitted that what they'd done had been wrong and agreed to conduct the discredited election over again.

The Tenth Concept's guarantee of the right to appeal for redress of a personal grievance is designed, in part, to protect those who exercise their Ninth Concept responsibility to speak their mind in service discussions. Together, the Ninth and Tenth Concepts support an atmosphere in which our members feel free to express themselves frankly on matters at hand. This open atmosphere is essential in developing an effective group conscience. If, after having demonstrated the courage of their convictions, individuals become the subject of reprisals initiated by those who have disagreed with them, the Tenth Concept allows them to petition the appropriate service body for redress of their grievance. Thus, the respect of our service structure for the rights of the individual NA member is guaranteed. In a fellowship such as ours, whose success is based upon mutual support and cooperation, that kind of respect for the individual is indispensable.

One such case involved a subcommittee member who exercised the responsibilities described in Concept Nine, speaking against a project proposed by the subcommittee chairperson. In the following months, the subcommittee chairperson stopped sending committee minutes and bulletins to the member, even neglecting to inform the member of the times and locations of future subcommittee meetings. The member contacted the subcommittee chairperson, asking that the problem be corrected. The chairperson refused. The subcommittee member decided to appeal to the area service committee for redress of a personal grievance against the chairperson.

The Tenth Concept is our fellowship's guarantee of respect for the individual trusted servant. If you think you've been wronged in the course of your participation in an NA service body and wish to apply Concept Ten, talk to your sponsor about it, inventory your own involvement in the matter, pray, and meditate. If, upon reflection, you still believe you have been personally aggrieved and that you should petition for redress, write a letter explaining the situation to your service body, or share your problem in the body's sharing session. The service body then needs to address the matter and, if it agrees that you have been wronged, how to make amends. Hopefully, the Tenth Concept will need to be applied only rarely in NA service. Should the need arise, however, it is here, ready to put our spiritual fellowship's ideals into action.

ELEVENTH CONCEPT

NA funds are to be used to further our primary purpose, and must be managed responsibly.

NA members around the world contribute money to help our fellowship fulfill its primary purpose. It is incumbent upon every element of our service structure to use those funds to carry the NA recovery message as far as possible. To do that, our service bodies must manage those funds responsibly, accounting fully and accurately for its use to those who have provided it.

Narcotics Anonymous funds should always be used to further our primary purpose. Money is used to pay the expenses involved in running NA recovery meetings, to inform the public about NA, and to reach addicts who can't get to meetings. It is used to develop, produce, translate, and distribute our message in written form, and to bring our members together in a service community committed to the vision of spreading our message around the world to those in need. All of this is done in support of NA's spiritual aim: to carry the message to the addict who still suffers.

Service funds aren't easy to come by. To fulfill our primary purpose, we need all of the financial resources at our fellowship's disposal. Our groups, service boards, and committees must make prudent use of the money we give them,

refusing to spend money frivolously or self-indulgently. With NA's primary purpose in mind, our services will avoid wasting money, using the funds they've been given to carry our message as effectively as possible.

One way we apply Concept Eleven is by establishing clear spending priorities and measuring each proposed expenditure against that priority list. Many groups, service boards, and committees have more items on their priority lists than their budgets will allow. In such cases, only the highest priorities can be funded.

Money is only one of the resources we must responsibly prioritize. While the Eleventh Concept applies directly to the management of funds, it also has implications for the management of all our service resources. Most projects depend as much on ideas, information, conscience, and members' time and willingness as they do on money. If we have the funds needed to carry out a project but lack the time or the ideas, we'd best wait until we've gathered all the needed resources before proceeding. If we don't, we will have wasted NA service funds. In responsibly planning and prioritizing our service efforts, we must consider the total resource picture, not just our finances.

In setting priorities, we may be tempted to look only at our own needs, tightly holding on to funds, spending money only on our own projects, and neglecting our role in providing needed funds to all levels of service. That kind of thinking is contrary to the Eleventh Concept. High on our list of priorities should be a commitment to further the goals of NA as a whole. For NA to deliver the services necessary to keep growing and fulfilling our primary purpose around the world, the flow of funds must not bottleneck at any point in our structure.

While groups are responsible to fund our services, they are also responsible to carefully manage their service contributions. When contributing money, groups should ask themselves what that money will do once it leaves their hands. Will it aid in the delivery of useful services to the groups? Will it help carry our message to the addict who still suffers? Will the service board or committee use it wisely? Our groups are free to decide for themselves how much they will contribute to the different levels of our service structure. We encourage them to do so, and to do so responsibly.

This is not to suggest that groups earmark contributions for any particular subcommittees. The groups have created the service structure not only to deliver services on their behalf, but to coordinate those services. In delegating to the service structure the authority necessary to fulfill its responsibilities, the groups have also delegated the authority to coordinate the allocation of service resources at each level of service. That way, the needs and goals of all fields of service can be effectively balanced against the total resources of the coordinating service body.

Clear, frank communication from our service structure is the best way to help our groups contribute their funds in a responsible way. When the groups receive full, regular reports on the activities of their service boards and committees, they begin to see the total service picture. The groups should also receive information on how much those activities cost. That kind of communication helps assure our groups that their contributions are being handled responsibly.

Direct group contributions to our service structure encourage responsible management of service funds and help our services maintain their focus on NA's primary purpose. It is our experience that, when we make a commitment to fund the work of each level of the service structure exclusively through group contributions, we find it easier to maintain a strong link between our groups and our other service units. Our groups tend to be more aware of the work being done on their behalf and of their responsibility to provide their boards and committees with the necessary financial resources. When all levels of our service structure receive direct financial support from the groups, the bonds of mutual responsibility are strengthened between them. Additionally, by freeing our service boards and committees from the need to engage in fundraising activities, we make it possible for those service units to devote their full energies to the fulfillment of NA's primary purpose.

Accountability is an essential aspect of responsible NA financial management. When the members of Narcotics Anonymous provide groups, committees, offices, and conventions with funds, our service structure is responsible to account for how those funds are used. Regular financial reports, open books, and periodic audits of NA accounts, as described in the various guides developed for NA treasurers, help our members be sure their contributions are being used well, and help our services remain financially accountable to those they serve. Treasurers' reports help us see how well our actual service spending matches up with the priorities we've established. Consistent financial records help us make realistic spending plans for future service activities. Regular financial reporting and auditing also help deter the theft of NA service funds; and if funds are stolen, regular audits ensure that such thefts cannot go long unnoticed.

When NA members contribute service funds, they expect their money to be used carefully, and to be used for the sole purpose of furthering our primary purpose. By accepting those contributions, our groups, service boards, and committees make a commitment to use those funds to carry the NA message, and to manage them responsibly.

TWELFTH CONCEPT

In keeping with the spiritual nature of Narcotics Anonymous, our structure should always be one of service, never of government.

Selfless service is an essentially spiritual endeavor. Our Twelfth Step says, in part, that "having had a spiritual awakening," we individually "tried to carry this message to addicts." Our collective service efforts arise from that same spiritual foundation. Having experienced the results of this program in our own lives, we join together to carry the recovery message farther than we could individually. NA service is not about forcing our will or our ideas on others; rather, it is about humbly serving them, without expectation of reward.

This principle underlies all we do in our groups, service boards, and committees. The Twelfth Concept reminds us that we ourselves have experienced recovery only because others put this selfless principle into action before us, taking the time and the care to carry the NA message to us when we were still suffering from active addiction. In service, we express our gratitude for the recovery others have shared with us by carrying ours to others. Nothing could be further from the drive to rule or direct than this spirit of selfless service.

Our groups were created because we found that, alone, we could not "stop using drugs, lose the desire to use, and find a new way to live." In the same way, our groups have joined together to create a service structure, a cooperative effort designed to help them carry the message further than they could carry it separately. The service structure has not been created as a way for some groups to force others to do their bidding. Rather, it has been developed to combine the strength of our groups to better fulfill necessary services which usually cannot be fulfilled well, if at all, by individual groups: developing and distributing materials that share our message in print, providing information about NA to the general public, transmitting our message to addicts who cannot attend meetings, and supporting new groups and new NA communities. NA service is the cooperative effort of trusted servants receiving guidance from the groups, not a rule enforced by a governing body.

The process of joining together to create the service structure is an expression of our groups' humility. Separately, they can do far, far less to fulfill our fellowship's primary purpose than they can do together. In the same way, the various elements of our service structure each play their own particular role in the broader Narcotics Anonymous service plan. All the elements depend on all the others for their effectiveness; when any one element attempts to act as an agency of government, rather than a vehicle for service, it strains the ties that bind us all together, threatening our fellowship's overall effectiveness in fulfilling

its primary purpose. Humility is an essential attribute of nongoverning service in Narcotics Anonymous.

In order to serve well, each element of our service structure must make an earnest effort at effective communication. As groups, as trusted servants, as service boards and committees, we must share fully with others, and listen carefully and respectfully to their words to us. Others may use language to divide the strength of their opponents, so that they may rule them; in NA service, we share with one another so that we may combine our strength, the better to fulfill our fellowship's primary purpose. To maintain our accountability to those we serve, we are bound to inform them in a complete, accurate, and concise fashion of our activities. The nongoverning nature of our service structure dictates that we seek others' advice in our own decisions, their consent in decisions affecting them, and their cooperation in decisions affecting us all. Open, honest, and straightforward communication nurtures the spirit of service in our fellowship, and poisons the impulse to govern.

The kind of authority that our groups have delegated to our boards and committees is the authority to serve, not to govern. Each element of our service structure, from the group to the world, has its own role to play; all, however, serve together as a team, striving toward a common goal, "that no addict seeking recovery need die without having the chance to find a new way of life." It is our sometimes hard-won experience that quality service, just like quality recovery, can only be accomplished in an atmosphere of mutual respect, mutual support, and mutual trust. Together, we recover, and together, we serve--this is the spiritual core of our program, the foundation of our fellowship. A structure based on that foundation could only be one of service, never of government.

NA SERVICE STRUCTURE

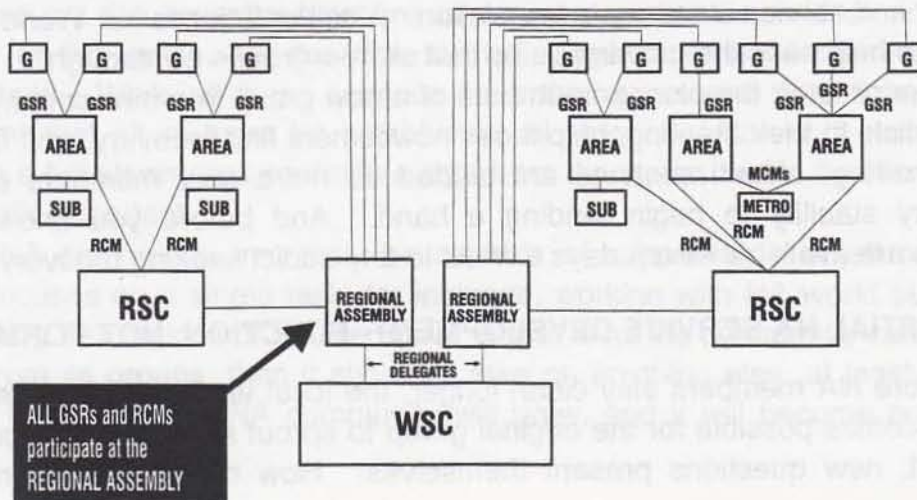

DEVELOPING NA COMMUNITIES

In many countries, the NA community is very young and very small; there is no area or regional committee, no phonenumber, no H&I program, no office. This chapter is aimed specifically at Narcotics Anonymous communities in those countries. The basic question it addresses is this: How does a developing NA community begin establishing the services which help carry our message to any addict seeking recovery?

In this chapter, we refer to "countries," "nations," and "national communities." We do this because, so far, most NA communities outside North America have organized their services along national lines. However, an NA community should feel free to organize services for a single territory within a larger federal union if doing so would be more practical and better serve our primary purpose. Likewise, if NA groups whose members speak the same language or have other cultural ties wish to unite in a single area or region covering a number of neighboring countries, we encourage them to do so.

THE FIRST GROUP

A new recovery community begins when a single group opens the door on the nation's first NA meeting. Most new groups, even those in established NA communities, grow slowly, and that can be frustrating. Contact with others who've been through the same experience can help reduce the frustration. NA world services can put the members of a new group in touch with addicts in other NA communities who will be happy to share their experience. Correspondence, visits, and cooperation with groups in neighboring countries, especially those whose people speak the same language, can be very helpful. World services can also provide other resources that may prove useful to a new group, such as recovery and service literature in translation. A call or letter to our World Service Office can help ease the growing pains that all new groups go through.

Sooner or later, the pioneer members of a new group in a new country attract other addicts to their meeting, help those newcomers find recovery, and find their group growing. New meetings are started as more new members gain the necessary stability to begin lending a hand. And before you know it, NA meetings are available seven days a week to any addict seeking recovery.

INITIAL NA SERVICE DEVELOPMENT--FUNCTION, NOT FORM

As more NA members stay clean longer, the local leadership base expands and it becomes possible for the original group to sprout a number of groups. At this point, new questions present themselves. How can the NA community

provide more and better services to its groups and members? And how can the recovery message be carried to more addicts? Five types of work present themselves:

Literature. The availability of NA books and pamphlets in the local language has proven very important to the growth of the fellowship and to informing others about Narcotics Anonymous. If literature is already available in translation from NA's World Service Office, all that needs to be done is ensure a steady supply. However, if NA literature has not yet been translated into the local language, or if only a few pieces are yet available, translation work will be of primary importance. Contact the World Service Office for help in beginning translation work in your country.

Public information. NA's contacts in government, education, medicine, the clergy, community organizations, the public media, and other twelve-step fellowships can carry the message that NA exists, sometimes to places we couldn't possibly go ourselves. Making such contacts and making them aware of what Narcotics Anonymous is, what we can do, and where our groups meet are very important factors in NA's growth.

Phonelines or central contact points. An NA telephone number or post office box can make it easier for addicts seeking recovery to find us and for our nonaddict friends to get more information on the NA program.

Hospitals and institutions. Panels can be formed to carry our message of recovery directly to addicts housed in medical, psychiatric, or correctional facilities.

Internal support. With the creation of new groups, some vehicle will have to be established for keeping them in touch with one another. By doing so, the groups can share their experience with one another, make decisions together regarding questions that affect them all, and combine their strength in reaching out to the community around them.

These are the essential functions of an *area service committee*. In another chapter of this guide, we describe the full range of services offered by area committees. While all these services have their place and their time, it is not important that all of them be established all at once. Nor is it necessary to develop a full-blown area committee right from the start. It's the function, not the form that's important.

An NA community may only be capable of supporting a small committee which focuses on a single task--for instance, working with NA world services in developing translations of NA literature. If that is all the community can support, aside from its groups, then it shouldn't take on anything else, at least not right away. With time, the NA community will grow, and it will become possible to

accomplish more tasks. But, especially at the start, remember: Keep your priorities in order.

It's not necessary for a new NA service effort to invent all its own tools from scratch. Other NA communities in other countries have gone through the same process. To tap their experience, simply contact NA's World Service Office.

THE NATIONAL COMMUNITY GROWS

As NA communities and service committees develop in other towns and other districts, the question arises: how does NA combine its experience and strength, maintain its unity, and carry its message further? This question is addressed in fully developed NA communities by area and regional committees. Still-developing communities will be long in forming a fully operational regional service committee; in some countries, for a variety of reasons, the NA community may choose not to organize a regional service committee, choosing instead to remain an area committee. The same principles which applied to developing local services--function, not form, and the importance of prioritizing--apply to developing services affecting a number of locales and the NA community nationwide.

What functions need to be accounted for?

Assemblies. Group service representatives from a number of locales can gather from time to time to coordinate outreach activities and discuss issues affecting NA on a territorial or national level. If a service body has been created to coordinate services affecting Narcotics Anonymous nationwide, such assemblies can give that national committee the guidance it needs to fulfill its responsibilities. If no such national entity has yet been organized, the GSRs can discuss national development issues and equitably divide responsibility for addressing those issues among themselves.

Central service coordination. Some NA services affect the fellowship nationwide. The production of translations of existing NA literature is one such responsibility. It is also in the best interests of the entire national community to responsibly handle requests for information or other services from national civic, professional, religious, and government organizations. Some means need to be created for coordinating these national services. These means may be as simple as the GSR assemblies described above. If enough leadership can be spared from group and local service responsibilities, a national area or regional committee might be formed. The national committee can either handle these services themselves or make arrangements for local groups to fulfill them.

Relations with NA worldwide. It's not necessary to funnel all communications between NA's world services and the national fellowship through one person or one small group of people--in fact, just the opposite. The benefits

derived from regular communications with NA world services and from contact with NA communities in other countries need to be shared with as many people as possible. In order to facilitate that, it may be helpful to establish a forum in which information gathered from those contacts can be shared. That forum may be as simple as a GSR assembly or as sophisticated as a full-fledged national region serving a number of local area committees--whatever the national community needs and is capable of supporting.

The regional-type services described elsewhere in the *Guide*--or the most important of them, anyway--don't have to be administered by a regional service committee. A national NA community doesn't need to wait until it can support a fully organized region before it can start addressing the needs of groups nationwide. Remember, it's the function that's important, not the form, so keep your priorities in order. It works--but not overnight.

THE NA GROUP

INTRODUCTION

Narcotics Anonymous groups are self-governing (the Twelve Traditions use the word *autonomous*). The group may conduct its own affairs in whatever way seems fit to its members, provided the group's actions do not adversely affect other groups or the entire NA Fellowship. So what we offer here is not a "rule book" but the shared experience of how many of our groups have met with success in conducting meetings and tending to business. Newer members may find this chapter helps them understand who does what to keep the group going and how to help. For more experienced members, it may lend some perspective to their group involvement. But no matter how much information we pack into this chapter, you're still going to find that the best source of guidance for your group is in your group itself.

There are many ways of doing things in Narcotics Anonymous. And just as all of us have our own individual personalities, so will your group develop its own identity, its own way of doing things, and its own special knack for carrying the NA message. That's the way it should be. In NA we encourage unity, not uniformity.

This chapter does not even attempt to say everything that could be said about operating an NA group. What you'll find here are some brief answers to a few very basic questions: What is an NA group? How does the work get done? What kinds of meetings can a group have? When problems arise, how are they solved? We hope this chapter proves useful as your group seeks to fulfill its primary purpose: to carry the message to the addict who still suffers.

WHAT IS AN NA GROUP?

When two or more addicts come together to help each other stay clean, they may form a Narcotics Anonymous group. Here are six points¹ based on our traditions which describe an NA group:

1. All members of a group are drug addicts, and all drug addicts are eligible for membership.
2. As a group, they are self-supporting.
3. As a group, their single goal is to help drug addicts recover through application of the Twelve Steps of Narcotics Anonymous.
4. As a group, they have no affiliation outside Narcotics Anonymous.
5. As a group, they express no opinion on outside issues.

¹ The six points describing a group have been adapted from "The AA Group," published by Alcoholics Anonymous World Services, Inc. Reprinted by permission.

6. As a group, their public relations policy is based on attraction rather than promotion.

In stating the six points that differentiate an NA group from other kinds of groups, we place greater emphasis on *drug* addiction than almost anywhere else in our service literature. This is because Narcotics Anonymous groups cannot be all things to all people and still provide the initial identification drug addicts need to find their way to recovery. By clarifying our groups' sole membership requirement and primary purpose in this way, once and for all, we free ourselves to focus on freedom from the disease of addiction in the bulk of our service literature, certain that our groups are providing adequate grounds for identification to those seeking recovery.

NA groups are formed by addicts who wish to support one another in recovery, in carrying the message directly to other addicts, and in participating in the activities and services of NA as a whole. One of the primary means an NA group uses to fulfill these ends is to conduct NA meetings where addicts can share their recovery experience, thus supporting one another and at the same time carrying the message to others. Some groups host a single weekly meeting; others host a number of meetings each week. The quality of an NA meeting is directly dependent on the strength and solidarity of the NA group which sponsors it.

NA groups--not NA meetings--are the foundation of the NA service structure. Together, the NA groups are responsible for making service decisions that directly affect them and what they do in their meetings as well as those that fundamentally affect the identity of Narcotics Anonymous. For instance, new NA literature is approved by regional delegates at the World Service Conference only after they have received direction from the groups they represent. Likewise, "proposals to change NA's Twelve Steps, Twelve Traditions, name, nature, or purpose should be approved directly by the groups" before they can become effective, in accordance with our Second Concept.

Groups maintain contact with the rest of Narcotics Anonymous through representatives selected to participate on the groups' behalf in the NA service structure. Mailings from the World Service Office, including the quarterly *NA Way Magazine*, keep NA groups informed on issues affecting the fellowship worldwide. If your group is not receiving *The NA Way Magazine*, ask your secretary to contact the World Service Office.

The primary purpose of an NA group is to carry the message of recovery to the addict who still suffers. The group provides each member with the opportunity to share and to hear the experience of other addicts who are learning to live a better way of life without the use of drugs. The group is the primary vehicle by which our message is carried. It provides a setting in which a

newcomer can identify with recovering addicts and find an atmosphere of recovery.

Sometimes specialized NA groups form to provide additional identification for addicts with particular needs in common. For example, many men's, women's, gay, and lesbian groups exist today. But the focus of any NA meeting--even if it's conducted by a specialized group--is on recovery from addiction, and any addict is welcome to attend.

NA meetings are events at which addicts share with one another their experience in recovery and in the application of the Twelve Steps. While many--if not most--NA meetings are in fact hosted by an NA group, other NA meetings occur all the time: informally among friends, at large area or regional speaker meetings, at conventions, in schools, institutions, and so forth. The NA group is an entity; the NA meeting is an event; and NA meetings may be held without the sponsorship of an NA group.

WHAT IS A "HOME GROUP"?

In some NA communities, it has become customary for members of the fellowship to make a personal commitment to support one particular group--their "home group." Though this custom is not universal, many believe its practice can benefit the individual member as well as the group. For the individual member, it can provide a stable recovery base, a place to call "home," a place to know and be known by other recovering addicts. For the group, it ensures the support of a core of regular, committed members. A strong home group can also foster a spirit of camaraderie among its members that makes the group more attractive to and more supportive of newcomers.

The home group provides many opportunities for us to involve ourselves in the NA Fellowship, making it a great place for us to start giving back what Narcotics Anonymous has so freely given us. In committing to our home group, we make a personal commitment to NA unity. That commitment not only enhances our own recovery, it helps ensure recovery is available for others. Our home group also gives us a place in which to participate in NA's decision-making processes.

While the home group concept is the accepted norm in some NA communities, it's unknown in others. There are many, many ways of talking and thinking about the bond established among addicts in their groups. Do what seems most suitable in your own NA community.

WHO CAN BE A MEMBER?

If an addict wants to be a member of Narcotics Anonymous, all that addict needs is a desire to stop using. Our Third Tradition ensures that. Whether an

individual NA member chooses to be a member of a particular group as well is entirely up to that individual. Access to the meetings of some NA groups is restricted by factors beyond the control of these groups--national border-crossing laws, for instance, or prison security regulations. However, these groups themselves do not bar any NA member from joining them.

WHAT ARE "OPEN" AND "CLOSED" MEETINGS?

"Closed" NA meetings are only for addicts or those who think they might have a drug problem. Closed meetings provide an atmosphere in which addicts can feel more certain that those attending will be able to identify with them. Newcomers may feel more comfortable at a closed meeting for the same reason. At the beginning of a closed meeting, the leader or chairperson often reads a statement explaining why the meeting is closed and offering to direct nonaddicts who may be attending to an open meeting.

"Open" NA meetings are just that--open to anyone who wants to attend. Some groups have open meetings once a month to allow nonaddict friends and relatives of NA members to celebrate recovery anniversaries with them. Groups that have open meetings may structure their format in such a way that opportunities for participation by nonaddicts are limited only to short birthday or anniversary presentations. Such a format allows the meeting to retain its focus on recovery shared one addict to another. It should be made clear during the meeting that NA groups do not accept monetary contributions from nonaddicts.

Some groups use carefully planned open meetings, particularly open speaker meetings, as an opportunity to let members of the community-at-large see for themselves what Narcotics Anonymous is all about and ask questions. At such public meetings, a statement regarding our tradition of anonymity is often read, asking visitors not to use full-face photographs, last names, or personal details when they describe the meeting to others. For more information on public meetings, see *A Guide to Public Information*, available through your group service representative or by writing the World Service Office.

WHERE CAN WE HOLD NA MEETINGS?

NA meetings can be held almost anywhere. Groups usually want to find an easily accessible public place where they can hold their meetings on a weekly basis. Facilities run by public agencies and religious and civic organizations often have rooms for rent at moderate rates that will meet a group's needs. Others in your NA community may already be aware of appropriate space available for your meeting; speak with them.

Most meeting facilities will be very cooperative and generous. Even though such facilities may want to donate meeting space to us, our Seventh Tradition

encourages our groups to be self-supporting by paying all our own expenses, including our rent. Some facilities may prefer their rent to be paid in literature or other services.

Before securing a location, it may be well to consider whether or not the room will be accessible to addicts with physical limitations. Does the building have ramps, elevators with wide doors, and bathroom facilities able to accommodate someone in a wheelchair? Is adequate parking and unloading space available? There are other similar considerations your group may wish to make itself aware of. For more information on reaching out and serving addicts with additional needs, write to the World Service Office.

It's generally recommended that group meetings not be held in members' homes. Most groups find it desirable to hold their meetings in public facilities for a variety of reasons. Stable meetings held in public places tend to enhance NA's credibility in the community. Because of varying work and vacation schedules, it is often difficult to maintain consistent times for meetings held in individuals' homes. Holding a meeting in an individual's home may affect the willingness of some members to attend. Although some groups may hold their first few meetings in a member's home, it's generally recommended that they relocate their meetings to public facilities as soon as possible.

Holding regular NA group meetings in some types of facilities--addiction treatment centers, clubhouses, or political party headquarters, for instance--can compromise the independent identity of the group. Before deciding to locate your meeting in such a facility, your group may wish to consider a few questions: Is the facility open to any addict wishing to attend the meeting? Does the facility administration place any restrictions on your use of the room that could challenge any of our traditions? Is it clear to all concerned that your NA group, not the facility, is sponsoring the meeting? Do you have a clear rental agreement with the facility management, and is the rent you're being charged moderate enough to allow your group to contribute funds to the rest of the NA service structure? Are so many of your community's NA meetings already located in this particular facility that, if it were to fold, your NA community as a whole would be crippled? These are some of the questions a group should carefully consider before deciding where to hold an NA meeting.

WHAT KIND OF MEETING FORMAT CAN WE USE?

Groups use a variety of formats to enhance the atmosphere of recovery in their meetings. Most meetings last an hour or an hour and a half. Some groups have a single format for their meetings. Other groups have a schedule of rotating formats: one week a step study, the next week a speaker meeting, and so forth. Still others divide their large meetings into several sessions after the meeting has

opened, each with its own format. Here are a few basic descriptions of some of the meeting formats that, with variations, seem to be among the most common. For reference, we've also included a sample meeting format at the end of this chapter.

Participation meetings

The leader opens the meeting up for members to share on any subject related to recovery.

Topic discussion meetings

The leader selects a particular recovery-related topic for discussion or asks someone else to provide a topic.

Study meetings

There are a number of different types of study meetings. Some read a portion of an NA-approved book or pamphlet each week and discuss it--for example, a Basic Text study. Others have discussions focusing on the Twelve Steps or the Twelve Traditions.

Speaker meetings

Some meetings ask a single speaker to share his or her recovery story or experience in a particular aspect of recovery in Narcotics Anonymous. Others ask two or three speakers to talk for shorter periods of time. Still others use a combination format with a speaker sharing first and a topic discussion afterward.

Newcomer meetings

These meetings are often conducted by two or three of the group's more experienced members. These members share their experience with addiction and with recovery in Narcotics Anonymous. If time allows, the meeting is then opened for questions from the newer members.

Newcomer meetings are sometimes held a half hour before or after the group's regular meeting. Other groups conduct them as smaller sections of a large meeting. Still others hold a newcomer meeting one day of the week, their regular meeting another. Whatever the format, newcomer meetings provide a means for your group to give addicts new to NA an introduction to the basics of recovery.

Question-and-answer meetings

At Q&A meetings, people are asked to think of questions related to recovery and the fellowship, write those questions down, and place them in "the ask-it basket."

The leader of the meeting pulls a slip of paper from the basket, reads the question, and asks for someone to share their experience related to it. After one or two members have shared, the leader selects another question from the basket, and so forth, until the meeting is over.

DEVELOPING YOUR FORMAT

These are basic descriptions of just a few of the many different types of formats used in NA meetings; the variations on even these few format types can be endless. Feel free to innovate. Vary the format in whatever way seems to best suit the "personality" of your group and the needs of addicts in your community.

Often, a meeting will grow far larger than the group originally anticipated. A meeting format that worked well for a small meeting may not work as well for a larger one. When one of your group's meetings experiences that kind of growth, you may want to consider making some adjustments in your format, perhaps even replacing it altogether. Some groups experiencing such growth break their larger meetings down into a number of small meetings held simultaneously in different rooms. Doing this gives each member a better chance to participate in whatever meeting he or she attends. Many groups use a different type of format in each of these smaller meetings.

WHAT KINDS OF LITERATURE SHOULD WE USE?

Various service boards and committees in Narcotics Anonymous produce a number of different kinds of publications. However, only NA-approved literature is appropriate for reading in Narcotics Anonymous meetings. Selections from NA-approved books and pamphlets are usually read at the beginning of an NA meeting, and some meetings use them as the core of their format. NA-approved literature represents the widest range of recovery in Narcotics Anonymous.

Groups often make other kinds of NA publications available on the literature tables at their meetings: various NA service bulletins and handbooks, *The NA Way Magazine*, and local NA newsletters. However, literature of any sort produced by other twelve-step fellowships or other organizations outside NA is inappropriate for display on our literature tables or reading at our meetings. To do either implies an endorsement of an outside enterprise, directly contradicting NA's Sixth Tradition.

WHAT IS A GROUP BUSINESS MEETING?

The purpose of the group business meeting is fairly self-explanatory: to conduct the business of the group in such a way that the group remains effective

in carrying the recovery message. Some groups hold business meetings on a regular basis; others only call them when something specific comes up that needs the group's attention. Some of the questions a typical group business meeting addresses are:

- * Is the group effective in carrying the NA message?
- * Are newcomers and visitors being made welcome?
- * Do solutions for problems at recent meetings need to be sought?
- * Is the meeting format providing sufficient direction?
- * Is attendance steady or growing?
- * Are there good relations between the group and the facility in which the meeting is held? Between the group and the community?
- * Are the group's funds being used wisely?
- * Is there enough money being donated at meetings to meet the group's needs and also provide for contributions to the rest of the service structure?
- * Are literature and refreshment supplies holding up?
- * Is there a service vacancy in the group?
- * Has the area, the region, or world services asked the group for advice, support, or direction?

Group business meetings are usually held before or after a regular recovery meeting so that the recovery meeting remains focused on its primary purpose. Group members are encouraged to attend, raise questions, and participate in discussions related to the group's work. The group selects someone to lead the business meeting. Group officers give reports on their areas of responsibility, and subjects of importance to the group are raised for discussion.

The group, as the foundation of the NA service structure, is guided by both the Twelve Traditions and the Twelve Concepts for NA Service. A good understanding of both will help a group business meeting stay on course. NA's step and tradition book, *It Works: How and Why*, provides a wealth of information about the Twelve Traditions. Interested members can read essays on the Twelve Concepts in another chapter of this guide.

HOW DOES THE WORK GET DONE?

Setting up chairs, buying literature, arranging for speakers, cleaning up after the meeting, paying the bills, preparing refreshments--most of the things an NA group does to host its meetings are pretty simple. But if one person had to do them all, those simple things would quickly become overwhelming. That's why a group elects officers (or, in the language of the Second Tradition, *trusted servants*): to help divide the work among the group's members.

Electing officers is one way the group practices NA's tradition of self-support: "Every NA group ought to be fully self-supporting..." Sometimes it seems that

groups run all by themselves, but the fact is that someone has to do the work needed to support the group. By dividing the work, the group ensures that the group as a whole is self-supporting and that the group's burdens don't settle unevenly on the shoulders of just one or two individuals.

Electing officers provides the group with an opportunity to strengthen its members' recovery. When group members agree to serve as secretary or treasurer or tea- or coffee-maker, that acceptance of responsibility often helps advance their personal growth. It also gives them a chance to help enhance the group's ability to carry the recovery message.

You don't have to be a group officer to be of service to the group. Every week, there's work to be done: helping set up the meeting, greeting newcomers, cleaning up, bringing refreshments, and other things of that sort. Asking new members to help with these kinds of jobs can make them feel a part of the group more quickly.

HOW DO WE CHOOSE GROUP OFFICERS?

When a vacancy occurs in a group office, the group holds a business meeting to consider how to fill it. Groups should arrange their elections in such a way that they don't have all their trusted servants leaving office at the same time.

There are a couple of things to think about when looking for a group officer. One is maturity in recovery. When those new in recovery are elected to a position, they may find themselves deprived of time and energy they need for their early recovery. Group members with a year or two clean are probably already well-established in their personal recovery. They are also more likely than new members to be familiar with NA's traditions and service concepts as well as group procedures.

A second thing to consider is consistent participation in your group. Do the nominees attend your group's recovery meetings regularly? Do they take an active part in your group's business meetings? Have they lived up to previous service commitments they've made? Further questions may occur to you as you read the earlier essay in this guide on NA's Fourth Concept for Service, which squarely addresses the importance of NA leadership and the qualities to consider in selecting trusted servants.

Finally, we encourage you to remember that you're selecting group officers, first, to benefit the common welfare of your group. While service commitments often benefit those who accept them, that should not be the primary reason for selecting one individual or another to serve as an officer of your group. As the First Tradition says, in part, "our common welfare should come first."

WHAT OFFICERS DOES A GROUP NEED?

In different areas the work is divided differently, and the particular jobs are sometimes called by different names. What's important is not who does the job or what the job is called, but that the job gets done. What follows are general descriptions of some of the most common sorts of jobs NA groups have. For each of these positions, your group should establish realistic terms of service and clean-time requirements.

Secretary

The secretary (sometimes called the chairperson) arranges the affairs of the group, often by asking other group members to help out. One of the first jobs for a new secretary is registering the group's current mailing address and meeting information with the area service committee secretary and the World Service Office. When a new group secretary or GSR takes office or there is a change in the group's mailing address or the time or location of a group meeting, both the area committee and World Service Office should be informed. Other things a group secretary is responsible for may include:

- * Opening the meeting room well before the meeting is scheduled to begin, setting up chairs and tables (if necessary), and cleaning and locking the room after the meeting is over.
- * Arranging a table with NA books and pamphlets, local meeting lists, NA activity fliers, service bulletins, *The NA Way Magazine*, and NA newsletters.
- * Making tea or coffee.
- * Buying refreshments and other supplies.
- * Selecting meeting leaders and speakers.
- * Keeping a list of group members' recovery anniversaries, if the group wishes.
- * Organizing group business meetings.
- * And doing whatever else needs to be done.

Many groups break all these jobs down separately: someone to open and close the room, another person responsible for refreshments, a third to take care of the literature table, and so forth. Groups that host more than one meeting will often have a different person responsible for all these jobs at each of their meetings.

Treasurer

All groups, even those that host more than one meeting, elect one group treasurer. When the group consolidates responsibility for all its funds under a single treasurer, the group makes it easier to account for the contributions it receives and expenses it pays than if it gives a number of individuals responsibility for its money. Groups that host two or more weekly meetings

should make arrangements for contributions to be passed to the group treasurer shortly after each meeting.

Because of the added responsibility of handling money associated with service as a group treasurer, it's important that groups look carefully at those they elect as treasurers. If the group elects someone who is not capable of handling the responsibilities of the job, then the group is at least partly responsible if money is stolen, supplies aren't purchased, or funds aren't properly accounted for. It's recommended that groups elect treasurers who are financially secure and are good at managing their personal finances. Because of the need to keep consistent records, it's also strongly recommended that groups elect treasurers to serve for a full year.

What do group treasurers do? They count the money that members have contributed at each meeting, always asking another member to confirm their count. They take special care not to confuse the group's money with their own personal funds. They pay expenses, keep good, simple records, and regularly provide financial reports to their groups. The group treasurer's job requires close attention to details. To help the treasurer in managing those details, a *Group Treasurer's Handbook* is available from your area committee or from the World Service Office.

Group service representatives (GSR)

Each group elects one group service representative; even those groups hosting more than one recovery meeting elect just one GSR. These GSRs form the foundation of our service structure. GSRs provide constant, active influence over the discussions being carried on within the service structure. They do this by participating in area service committee meetings, attending forums and assemblies at both the area and regional levels, and sometimes joining in the work of an ASC subcommittee. If we are vigilant in choosing stable, qualified leaders at this level of service, the remainder of the structure will almost certainly be sound. From this strong foundation, a service structure can be built that will nourish, inform, and support the groups in the same way that the groups nourish and support the structure.

Group service representatives bear great responsibility. While GSRs are elected by and accountable to the group, they are not mere group messengers. They are selected by their groups to serve as active members of the area service committee. As such, they are responsible to act in the best interests of NA as a whole, not solely as advocates of their own groups' priorities.

As participants in the area committee, GSRs need to be as well informed as they can be concerning the affairs of the committee. They study the reports of the committee's officers and subcommittee chairpersons. They read the various

handbooks published by the World Service Office on each area of service. After carefully considering their own conscience and what they know about how their group members feel, they take active, critical parts in the discussions which form the group conscience of the entire committee.

Group service representatives link their groups with the rest of the NA service structure, particularly through the information conveyed in their reports to and from the area committee. At group business meetings, the GSR report provides a summary of area committee activities, often sparking discussions among group members that provide the GSR with a feel for how the area can better serve the group's needs. In group recovery meetings, GSRs make available fliers announcing area and regional activities.

At area committee meetings, GSR reports provide perspectives on group growth vital to the committee's work. If a group is having problems, its GSR can share those problems with the committee in his or her reports. And if the group hasn't found solutions to those problems, the area chairperson will open a slot on the committee's "sharing session" ² agenda so that the GSR can gather the experience others have had in similar situations. If any helpful solutions arise from the sharing session, the GSR can report those back to the group.

Alternate GSR

Groups also elect a second representative called an alternate GSR. Alternate GSRs attend all the area service committee meetings (as nonvoting participants) with their GSRs so that they can see for themselves how the committee works. If a GSR cannot attend an area committee meeting, that group's alternate GSR participates in the GSR's place.

Alternate GSRs, along with other members, may also serve on area subcommittees. Subcommittee experience gives alternate GSRs added perspective on how area services are actually delivered. That perspective helps make them more effective area committee participants if their groups later elect them to serve as GSRs.

ROTATION AND CONTINUITY

Rotation is the practice many groups have of electing new people to service positions at set intervals rather than having the same person serve in the same position year after year. Rotation offers very definite benefits for the groups who practice it. By providing diversity in leadership, it helps a group stay fresh and energetic. It provides assurance that no one individual exercises so much influence that the group becomes a mere extension of his or her personality. The practice of rotation also reinforces the NA emphasis on service rather than the

² In the chapter on the area service committee, see the section entitled "The Sharing Session."

servant, consistent with our belief in the value of spiritual anonymity--what's important is the job being done, not the particular person doing it.

Some groups allow their members to serve more than one term in any given position so that the group can take advantage of its trusted servants' experience. Once group officers have completed their terms, rotation allows them to step aside for a time or accept responsibilities elsewhere in the NA service structure, giving other members the chance to serve the group.

The impact of rotation on the stability of the group is balanced by the continuing presence of its long-term group members. Those who have served in the past as group officers and continue to maintain an active role in the life of the group can provide much-needed continuity and maturity of perspective to a growing group's discussions. They can serve as the group's memory, ensuring that the group never has to "reinvent the wheel." They can also lend a hand to new officers and temporarily pitch in to relieve overloaded trusted servants.

WHAT RESPONSIBILITIES DOES AN NA GROUP HAVE?

The first and most important responsibility of any NA group--its "primary purpose," according to the Fifth Tradition--is "to carry the message to the addict who still suffers." And the single most important thing a group can do to fulfill that primary purpose is to conduct meetings that provide a welcoming atmosphere in which NA recovery can be effectively shared between addicts. Groups conduct the details of their meetings in very different ways, but all of them seek the same end: to make recovery from addiction available to any addict in the community who seeks it.

As the foundation of the worldwide NA service structure, groups have another responsibility: to help their members develop an understanding of the Twelve Traditions and the Twelve Concepts for NA Service. By doing so, groups take part in the continuing evolution of the Fellowship of Narcotics Anonymous as well as providing for themselves an understanding of how the highest ideals of our fellowship can be applied in their activities.

HOW CAN OUR GROUP SUPPORT OTHER NA SERVICES?

The Second Concept for NA Service says that the NA groups bear the final responsibility and authority for all the services of the extended NA Fellowship. Each group should send stable, active GSRs to participate in the work of the service structure on the group's behalf. And each group should consider how best to provide the funds the NA service structure needs to do its work.

After paying the bills, most groups set a small amount of money aside to use in case an emergency arises. But, oddly enough, groups usually find that too

much money in the till causes far more trouble than too little money. For this reason, we encourage your group never to hold large sums of money in reserve.

At least once a year, the group service representative attends the regional assembly. Each group is encouraged, if at all possible, to take the necessary steps to cover the expenses associated with its GSR's attendance at the regional assembly. Some groups will choose to set aside money each month toward this expense.

After paying expenses and setting aside a small emergency reserve, most groups contribute their surplus funds directly to the area committee, the regional committee, and NA's world services. For more discussion of the principles underlying group contributions to the rest of the service structure, see the essay on our fellowship's Eleventh Concept for Service elsewhere in this guide. For assistance in managing the details of direct contributions, see the *Group Treasurer's Handbook*, available from your area committee or by writing our World Service Office.

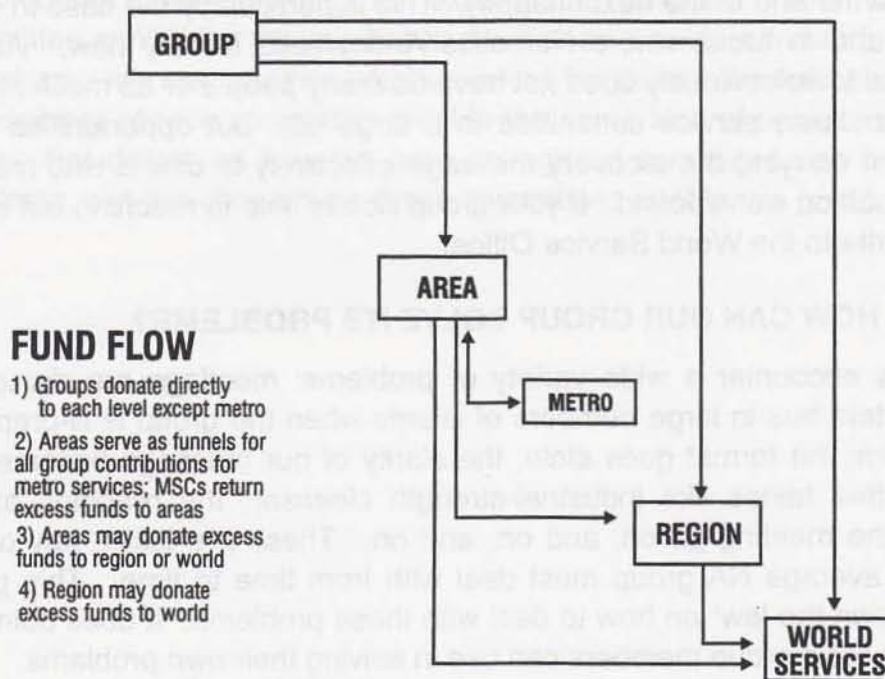

HOW CAN OUR GROUP BETTER SERVE OUR COMMUNITY?

By its very existence, the group is already providing a substantial service to the community. It's providing the support addicts in the community need to reenter the mainstream of society. But how can a group become more effective

in reaching out to addicts who've not yet found NA? There are two general ways in which a group can better serve its community: through the area service committee and through activities coordinated by the group itself.

Most NA groups are served by an area committee.³ Area service committees coordinate efforts to carry the NA message on behalf of all the groups they serve. Community public information services, telephone contact lines, and panel presentations to addicts in treatment centers and jails are three ways in which most area committees carry the message either directly to the addict who still suffers or to those who may refer an addict to an NA meeting. Your group service representative can tell you more about how you and your group can more effectively join in the work of your area service committee. For further information, see the next chapter in this guide.

Some NA groups reach out to their communities themselves, coordinating their activities with those of other groups either through their ASCs or through local cooperative councils (see the "Area Committees in Rural Communities" section toward the end of the next chapter). This is particularly the case in small communities and in areas where Narcotics Anonymous is very new. An NA group in a rural town obviously does not have as many people or as much money available as an area service committee in a large city, but opportunities exist nonetheless for carrying the recovery message effectively to others who may be seeking the solution we've found. If your group needs help in reaching out to the community, write to the World Service Office.

HOW CAN OUR GROUP SOLVE ITS PROBLEMS?

NA groups encounter a wide variety of problems: meetings are disrupted; treatment centers bus in large numbers of clients when the group is ill-prepared to receive them; the format goes stale; the clarity of our message becomes an issue; the coffee tastes like industrial-strength cleanser; the readings at the beginning of the meeting go on, and on, and on. These are just a few of the problems the average NA group must deal with from time to time. This guide doesn't "lay down the law" on how to deal with these problems. It does point out some effective tools group members can use in solving their own problems.

The best source of solutions for the group's problems, in most cases, is the group itself. "Having had a spiritual awakening as a result of these steps," our Twelfth Step says, "we tried... to practice these principles in all our affairs." When we collectively apply the insight received from that spiritual awakening to our group's problems, we call that *group conscience*. Common sense, open minds, calm discussion, accurate information, mutual respect, and healthy

³ If you don't know how to contact the nearest area service committee, write to the World Service Office. They'll be happy to put you in touch.

personal recovery enable a group to deal effectively with almost anything that comes its way.

There are a number of printed resources the group may choose to use in gathering the information it needs to reach sound decisions. The Basic Text and our step and tradition book, *It Works: How and Why*, both provide a great deal of information about how NA's Twelve Traditions can be applied to given situations. The chapter in this guide on the Twelve Concepts for NA Service gives in-depth explanations of the essential ideals underlying service activities in Narcotics Anonymous. *The NA Way Magazine* often has articles addressing problems the group might face. And bulletins available from the World Service Office deal in detail with a variety of subjects relating to the group's work.

Another source of information the group might tap is the experience of other groups in its area or region. If the group has a problem and can't come up with its own solution, it might want to ask its group service representative to share that problem at the next area service committee meeting. Area committees set aside a portion of every meeting for exactly that purpose. And while the area committee can't tell a group what to do, it does provide a forum in which groups can share with one another what's worked for them. Workshops conducted by the regional service committee provide the same kind of opportunity on a larger scale. For details on how the area or regional committee can help with group problems, see the chapters on those committees later in this guide.

SAMPLE MEETING FORMAT

This sample meeting format is just that--a sample. It's designed so that, if your group chooses, you can use it exactly as it is. However, you're encouraged to change it and rearrange it according to the needs of your group.

Leader:

Welcome members to the meeting and introduce yourself. Hello, my name is _____, and I am an addict. Welcome to this meeting of the _____ Group of Narcotics Anonymous. I'd like to open this meeting with a moment of silence (*15 to 20 seconds*) for the addict who still suffers, followed by the Serenity Prayer.

We like to extend a special welcome to newcomers. If anyone here is attending their first NA meeting, would you care to introduce yourself? We ask this not to embarrass you, but to get to know you better.

Is anyone here in their first thirty days of recovery? *Introductions.*

Do we have any out-of-town visitors? *Introductions.*

Is there anyone attending this meeting for the first time? *Introductions.*

If this is a closed meeting: This is a "closed" Narcotics Anonymous meeting. Closed NA meetings are only for addicts or those who think they might have a drug problem. If there are any nonaddicts visiting, we'd like to thank you for your interest in Narcotics Anonymous. Our local NA meeting list on the literature table will direct you to an NA meeting in our community that is open to nonaddicts.

If this is an open meeting: This is an "open" Narcotics Anonymous meeting. We'd like to welcome any nonaddict visitors and thank you for your interest in Narcotics Anonymous. We ask that you respect the primary purpose of this meeting, which is to provide a place where addicts can share their recovery with one another.

Leader:

For the protection of our group as well as the meeting facility, we ask that you have no drugs or paraphernalia on your person at the meeting. If you have any now, please leave, dispose of them, and return as quickly as possible.

Leader:

Recognize those with various periods of clean time--thirty, sixty, ninety days, six months, nine months, one year, eighteen months, and multiple years. Keytags, chips, or medallions may be given out.

Leader:

Select people before the meeting to read one or more of the following short pieces. These readings can be found in our White Booklet, the Basic Text, IP No. 1, or the group reading cards.

- a) Who Is An Addict?
- b) What Is The NA Program?
- c) Why Are We Here?
- d) How It Works
- e) The Twelve Traditions
- f) Just for Today

Leader:

Announce the type of meeting (participation, topic discussion, step study, speaker, etc.). Ask for topic or step and open the meeting for discussion, or introduce the speaker.

Leader:

About ten minutes before the meeting is scheduled to close, announce: That's all the time we have. I'd like to thank you for attending.

Leader:

Begin passing the basket around, announcing: The basket being passed around is one way of practicing our Seventh Tradition, which says, "Every NA group ought to be fully self-supporting, declining outside contributions." The money we collect pays for rent, literature, and refreshments. Through contributions from this group to various NA service committees, it also helps carry the NA message of recovery in our area and around the world.

If this is an "open" meeting: I'd like once again to thank our nonaddict guests for the interest they've shown in Narcotics Anonymous. Because of NA's tradition of self-support, this group asks that you not contribute any money when the basket passes your way.

Leader:

Do we have any NA-related announcements? (The GSR will make announcements of upcoming group activities and NA events in the area.)

Leader:

After the basket has come back around: Again, thanks for coming tonight. Would all those who care to, join in a circle to close? *Various groups close in different ways: with prayers, brief recitations from NA literature, etc.*

When closing their meetings, some groups ask those attending to respect the anonymity of others they've seen and heard there.

Keep coming back. It works!

So, you're starting a new group. Most of what you need to know about NA groups and Narcotics Anonymous meetings can be found in the chapter entitled "The NA Group" immediately preceding this checklist. We suggest that you and your fellow group members read through that chapter together so that you're all thoroughly familiar with the issues other NA groups have faced in trying to carry the message. This bulletin is a checklist of the things most groups feel are important to line up before opening their first meeting.

— **Get in touch with the nearest service committee.** An area committee meeting is the ideal place for announcing your intention to start a new group. There, you can gather experience from representatives of other groups in the area, and learn of the services available to your group when you need them.

— **Obtain a meeting place.** "The NA Group" chapter of this guide already discusses many of the things to be considered about obtaining meeting space. Here are some of the things to be nailed down when opening a new meeting:

* **Where?** _____

* **When?** Day, time, and duration of the meeting. _____

* **How much?** What is the facility charging for rent? _____

Is that realistic, keeping in mind the number of people you can expect to attend the meeting? _

When is the rent due? _____

* **What does the facility require?** No smoking? *Absolutely* no litter? Sweep, mop after the meeting? Close windows, lock doors? _____

* **Can your group's mail be sent to the facility address?** Will they set up a box where you can pick up newsletters and announcements mailed to your group? _____

— **Name your group.** A few things you may want to consider are: Is the name recovery oriented? Does the name create the impression that the group is affiliated with the facility in which it holds its meetings? _____

— **What group trusted servants are needed? What does the group expect those people to do?** The chapter on "The NA Group" gives descriptions of a number of group officers. Make sure all group members agree on what they want *their* officers to do.

— **What kind of meeting format will you use?** "The NA Group" chapter describes a number of format variations commonly used in our fellowship. Which format--or combination of formats--does your group want to use? _____

— **Will this be a "closed" NA meeting? Or an "open" meeting?** For explanation of these two different types of meetings, see the chapter on "The NA Group." _____

— **What kinds of NA literature does your group want to stock?** _____

— **What kinds of refreshments should be purchased?** _____

— **Have you registered your group with the World Service Office? The secretary of your area service committee?** Enclosed, you'll find a WSO group registration form. By filling it out and mailing it in, you'll ensure that your group is kept in touch with NA as a whole. You'll also be mailed *The NA Way Magazine*.

Also available from WSO:
Group Treasurers Workbook
NA Literature Sample Kit
Local service contact information

For more information, write or call:
Group Services
World Service Office
PO Box 9999
Van Nuys, CA 91409 USA
Telephone (818) 773-9999
Fax (818) 700-0700

NARCOTICS ANONYMOUS NEW GROUP REGISTRATION FORM

If you are updating group information, please use the "Group Update Form."

PLEASE PRINT!

Meeting Information

Area: _____ Region: _____

Meeting Day: _____ Time: _____ [] A.M. [] P.M.

Type of Meeting: _____ [] Open [] Closed

Place: _____

Address: _____

City: _____

Borough/Sub-City: _____

State/Prov: _____ Postal/Zip: _____

Country: _____

Does this group offer:

Wheelchair-accessibility? [] yes [] no

ASL Interpreter? [] yes [] no

Sight impaired services? [] yes [] no

Group Mailing Information

The following information is necessary for any communications with the group. Please list the information for the contact person or PO Box where your group should receive its mail.

Group Name: _____

(ASC or Contact Name:) _____

Address or PO Box: _____

City: _____

State: _____ Postal/Zip: _____

Phone: (_____) _____

Please mail this form to:

NA WORLD SERVICE OFFICE
P.O. Box 9999
Van Nuys, CA 91409

NARCOTICS ANONYMOUS GROUP UPDATE FORM

Group Code: _____ If the group is being registered for the first time, please use the "New Group Registration Form."

PLEASE PRINT!

Meeting Information

Area: _____ Region: _____

Type of Meeting: _____ [] Open [] Closed

OLD

NEW

Meeting Day: _____

Time: _____

Place: _____

Address: _____

City: _____

Borough: _____

State: _____

Zip: _____

Country: _____

Does this group offer:

Wheelchair-accessibility? [] yes [] no

ASL Interpreter? [] yes [] no

Sight Impaired services? [] yes [] no

Group Mailing Information

Please list the information for the contact person or area/group PO Box.

Group Name: _____

(ASC or Contact:) _____

Address: _____

City: _____

State: _____

Zip: _____

Phone: (_____) _____ (_____) _____

Please mail this form to:

NA WORLD SERVICE OFFICE
P.O. Box 9999
Van Nuys, CA 91409

THE AREA SERVICE COMMITTEE

Note: *If your area is a member of a metropolitan services committee, this chapter will not apply directly to your ASC. Please see the chapter on MSCs first for a description of area committees like yours.*

INTRODUCTION

"Workhorse" of the service structure--maybe that's the best way to describe the area service committee. Most of the hands-on work of delivering NA services to the groups and the community occurs at the area level.

NA groups support meetings where addicts can share their recovery with one another. Only minimal organization is necessary to hold those meetings. But there's lots more that can be done to further the aims of Narcotics Anonymous:

- * NA panel presentations at addiction treatment centers and correctional facilities can reach addicts particularly in need of what we have to offer.
- * Public information presentations to schools and community groups, mailings to addiction treatment professionals, meeting notices in newspapers, and public service announcements on local radio and television stations can help direct people to NA.
- * Directories showing where and when NA groups in the area hold their recovery meetings can help addicts and others find nearby meetings being conducted at times convenient to them.
- * A phonenumber service can help addicts seeking recovery find a meeting in their area. It can also provide information about NA to interested community members.
- * A ready supply of NA books and pamphlets can make it easier for groups to stock their literature tables.
- * Social activities can help addicts feel more comfortable in their local NA community and increase unity and camaraderie among area members.¹

All of these services require a certain degree of organization, the complexity of which could easily divert NA groups from the week-in, week-out task of conducting Narcotics Anonymous meetings for their members. Most of these services also require more money and manpower than any single group could possibly muster. How do groups stay focused on their primary purpose and still see that these other services are developed and maintained? In the words of NA's Ninth Tradition, they "create service boards or committees directly responsible to those they serve." And the service committee closest to home,

¹ Various handbooks describing these and other local services are available from the World Service Office. For further information, see the section titled "Subcommittees" later in this chapter and the list of bulletins and handbooks available from the WSO at the end of this guide.

the committee best situated to provide the most direct service to the groups and the community, is the area service committee.

A newly formed area committee will not be able to provide the same level of service as a longer-established committee. That's only natural. A new area service committee should not expect to hit the ground running at full speed. The development of the full range of area services described in this chapter often takes a few years. Be patient and keep plugging; it's worth the effort.

Just as individual members of NA rely upon one another for support, so do area committees. New committees in particular can draw upon the experience of their neighbors in charting a course for local services, whether those neighbors be in the next county or the next country. New ASCs can also draw encouragement from their neighbors' assurance that, given time, effort, and the application of principles, "it works." None of us has to do it alone, not in personal recovery and not in service, not anymore.

THE AREA COMMITTEE AND OTHER NA SERVICES

Area service committees are ultimately responsible to the groups they serve. Narcotics Anonymous groups send group service representatives (GSRs) to serve on the area committee. While still maintaining final responsibility and authority for area services, they invest enough delegated authority in their GSRs--and through them, in the area committee--for the necessary work to get done.

NA groups also send money to the area committee, money needed to coordinate panels, maintain phonelines, and conduct public information activities. Through their contributions of money and manpower, the groups exercise both their responsibility and their authority for NA services.

How does the area service committee relate in turn to NA's regional and world services? In much the same way as the group relates to the area committee: through carefully selected representatives who are delegated the authority necessary for effective service.

AREA COMMITTEE PARTICIPANTS

There are three groups of participants in most area service committees: GSRs and their alternates, administrative officers, and subcommittee chairpersons. The Seventh Concept for NA Service says that "all members of a service body bear substantial responsibility for that body's decisions and should be allowed to fully participate in its decision-making processes." Group service representatives provide a "grass roots" perspective to the area decision-making process, helping ensure that the committee's feet are planted firmly on the ground. Administrative officers and subcommittee chairpersons also bear substantial responsibility for the fulfillment of area services. Their ongoing

growth and experience in carrying out their duties is an invaluable resource to the area as it develops and expresses its group conscience. We ought never allow a base of valuable experience to be created without utilizing it to the fullest. Each area is responsible to create its own decision-making plan. In doing so, area committees should carefully consider the Seventh Concept.

GROUP SERVICE REPRESENTATIVES (GSRs)

Group service representatives link their groups to the rest of Narcotics Anonymous. Most groups also elect an alternate GSR who can fill in for the group representative when needed. GSRs serve a dual role. As our fellowship's Second Concept for Service indicates, GSRs take part on their groups' behalf in the area committee and the regional assembly, conveying a sense of their groups' wishes to the service structure and bringing back information on what's happening in the larger world of NA. Yet our Twelve Concepts also suggest that GSRs are delegated the authority to serve in their own right as ASC and regional assembly participants, exercising their own conscience and best judgment in the best interests of NA as a whole. For more information on the GSR's job, see both the Twelve Concepts for NA Service and the chapter on the NA group appearing earlier in this guide.

Basic equipment for group service representatives usually includes copies of *A Guide to Local Services in Narcotics Anonymous*, area guidelines (if the area has them), and the log of area policy actions (available from the area secretary). Qualifications and terms of service for GSRs are determined by the groups which elect them.

ADMINISTRATIVE OFFICERS

Many area service committees have six administrative officers: a chairperson, a vice chairperson, a treasurer, a secretary, and two regional committee members (RCMs). Areas belonging to a metropolitan services committee also have one or more metropolitan committee members (MCMs). (See the chapter later in this guide for information on metro committees and the role of MCMs.) These individuals are responsible for administering the general affairs of the entire area committee. Because of that, it's important that great care be taken in their selection. A substantial amount of clean time and personal maturity should be the first consideration, along with experience in the steps, traditions, and concepts of service. Our trusted servants should demonstrate the stability and personal sense of direction that serve as an example to others. They should be capable of serving without attempting to govern. The specific amount of clean time required for each office will vary from area to area according to how long the local NA community has been in existence.

Significant area service background often makes more effective administrative officers. Experience both as a group service representative and an area subcommittee member is helpful. Recent leadership experience as a subcommittee chairperson will prove invaluable. For more discussion of the role of leadership in NA services, see the essay on Concept Four in the chapter on the Twelve Concepts for NA Service appearing earlier in this guide.

Chairperson

The area committee chairperson is responsible for conducting committee meetings, preparing the agenda, and various administrative duties. The chair's primary tools are the short-form rules of order which appear at the end of this guide, a firm hand, a calm spirit, and a clear mind. The chairperson can find additional help in books about business meetings, decision-making processes, and volunteer organizations that are often readily available at local bookstores and libraries.

Vice chairperson

The primary responsibility of the area committee vice chairperson is the coordination of the area subcommittees. The area vice chair keeps in regular touch with the chairpersons of each subcommittee to stay informed of their projects and problems, attending subcommittee meetings whenever possible. If disputes arise within a subcommittee or between subcommittees, the ASC vice chair helps find solutions to them. The vice chairperson works closely with subcommittee chairs when they prepare their annual reports and budget proposals.

The vice chairperson is also responsible to assist the chairperson in conducting area committee meetings and to conduct ASC meetings him or herself in the chairperson's absence.

Secretary

Area secretaries handle all their committees' paperwork, a formidable job. Their first responsibility is to take clear, accurate minutes of area committee meetings and distribute those minutes to all committee participants within a reasonable period of time after each meeting.

In the process of keeping the minutes of each meeting, secretaries should regularly update a log of area policy actions. The log lists motions the committee has passed regarding the activities of administrative officers and subcommittees. These motions should be listed chronologically under a heading for the officer or subcommittee they affect. Secretaries should have copies of the most recent

printing of the log of policy actions available for new GSRs and should periodically distribute updated versions to all area committee participants.

Because most secretaries mail minutes to area committee members, they need to keep an updated list of participants' addresses. With their committees' permission, they should mail copies of these lists once or twice a year to the World Service Office. These lists will make it possible for the WSO to provide groups, subcommittees, and administrative officers with current information pertinent to their areas of service.

Treasurer

The area treasurer's job is critical to the committee's work. Because of the added responsibility of handling money associated with service as treasurer, it's especially important that area committees select their treasurers with care. If the committee selects someone who is not capable of handling the job, then the committee is at least partly responsible if money is stolen, area expenses are not paid, or funds aren't properly accounted for. It's recommended that areas elect people to this position who are financially secure, good at managing their personal finances, inspire the trust of the committee, and have substantial clean time. Experience in business, accounting, bookkeeping, or as a successful group treasurer is also very helpful.

The treasurer receives contributions from the groups, administers the area's checking account, pays the rent for the committee's meeting hall, reimburses officers and subcommittee chairs for their budgeted expenses, keeps careful records of all transactions, and reports on the financial condition of the area committee at each of its meetings. As the administrator of the area's unified general fund, the treasurer is also responsible to prepare an annual budget² for the area committee. The *Treasurer's Handbook*, available from the World Service Office, contains a more detailed description of the treasurer's job and most of the forms treasurers need for keeping their records.

Cash transactions can create a number of problems for ASC treasurers. Having large quantities of currency can make an area treasurer particularly vulnerable to robbery. Handling large undocumented sums of cash may also leave the treasurer open to unwarranted accusations of theft, or may even provide an unnecessary temptation. That's why we encourage groups to make their ASC contributions in the form of checks or money orders payable to the area service committee whenever possible. When treasurers receive cash contributions for their areas, they should always make out receipts to the contributors immediately, keeping copies for themselves with their official records.

² See the section later in this chapter, "Area Budgeting."

Wide experience also strongly suggests that, to help prevent theft, area committees should only use two-signature checks to pay their bills. In order for a check to be valid, it should be signed by the treasurer and another ASC administrative officer.

These cautions are offered to protect the treasurer from controversy as well as to protect area funds. Discussions of other considerations relating to both the treasurer's responsibilities and area finances appear later in this chapter. Readers can find more on general NA funding issues, including security and accountability, in the essay on Concept Eleven appearing in the chapter on the Twelve Concepts for NA Service earlier in this guide.

Regional committee members (RCMs)

Regional committee members are just that: They serve as the core of the regional service committee, a body which coordinates service forums throughout the region, is responsible for the regional convention, and conducts the regional assembly. The regional committee also serves year 'round as a contact point between NA world and local services. Detailed information on the services provided by regional committees can be found later in this guide.

RCMs keep their areas in touch with the larger world of NA by providing information on activities in neighboring areas, functions being sponsored by the regional committee, reports relevant to subcommittee affairs, and important issues being discussed at various levels of service.

Both the region and its areas depend on RCMs to be well-versed in NA service practices and principles. RCMs should be closely acquainted with the Twelve Traditions and Twelve Concepts, the fundamentals of service in our fellowship. Familiarity with all published service manuals and bulletins puts the resources of the whole fellowship at the RCM's fingertips.

RCMs should carefully study the reports from their own areas' groups, officers, and subcommittee chairs so that they can pass their areas' experience on to others at the regional meeting. RCMs will be more effective contacts between their areas and the regional committee if they take time to talk personally with other participants in their area committees. That way, they can get a better idea of what needs and concerns the regional committee should address.

Regional committee members serve two-year terms. Most areas have two RCMs serving at any one time, one elected in odd-numbered years and the other in even years. This helps regional committees maintain a balance between experienced members and those just learning the ropes. It also ensures that a regional committee serving only three or four areas will have enough members to be able to do its work.

ELECTIONS AND ROTATION

Some area committees hold elections for all their officers and subcommittee chairpersons at the same time each year; others stagger their elections, selecting members for different trusted-servant roles at different times of the year, so that their committees always have a mix of new and experienced leaders. Administrative officers and subcommittee chairpersons generally serve no more than two terms consecutively in the same position and, with the exception of RCMs, usually serve one-year terms. This allows for the rotation of a variety of individuals through an area's trusted-servant positions, providing a diversity of viewpoints and talents and a freshness of perspective that would be lacking were these positions to be held year after year by the same individuals. The rotation of trusted servants at the area level also helps the committee better reflect the full range of insight available among committee members, preventing the area committee from becoming the mere extension of an individual's personality. Rotation emphasizes that our efforts to help carry the message through service involvement is just one way of practicing our Twelfth Step, no more or less special or praiseworthy than any other. The practice of rotation is founded on this fellowship's belief that service is more important than the servant, an extension of our tradition of spiritual anonymity.

Area committees can foster continuity in their services by a number of means. As mentioned in the previous paragraph, some area committees stagger their elections of trusted servants, ensuring these committees always have a certain proportion of experienced leaders. Many area committees also encourage those who have completed terms as administrative officers and subcommittee chairs to remain active in the ASC either in another leadership position, as individual members of one of the area's subcommittees, or informally. By balancing the practice of rotation with the kind of experience available from past officers, an area committee can partake of the best of both worlds.

SUBCOMMITTEES

In some ways, the relationship between an ASC and its subcommittees is very similar to the relationship between NA groups and their ASC; in others, it is quite different. Just as groups create an area committee to help them fulfill their primary purpose, so the ASC creates subcommittees to do the actual work involved in delivering its direct services--H&I, PI, phonedines, activities, and the rest. If area subcommittees are to serve effectively, the ASC must delegate them sufficient authority to exercise their best judgment in fulfilling their duties. However, because an area committee must account to the groups for the actions of its subcommittees, ASCs generally maintain a somewhat tighter rein on their subcommittees than groups do on their area committees.

The balance between accountability and delegation is a delicate one. If an area committee exerts too much control over its subcommittees, those subcommittees will not be able to serve well. If the ASC delegates too much authority to its subcommittees, on the other hand, the area committee will not be able to account fully for itself to the groups it serves. An ASC should pay careful attention to the Twelve Concepts, especially Concept Five, when creating

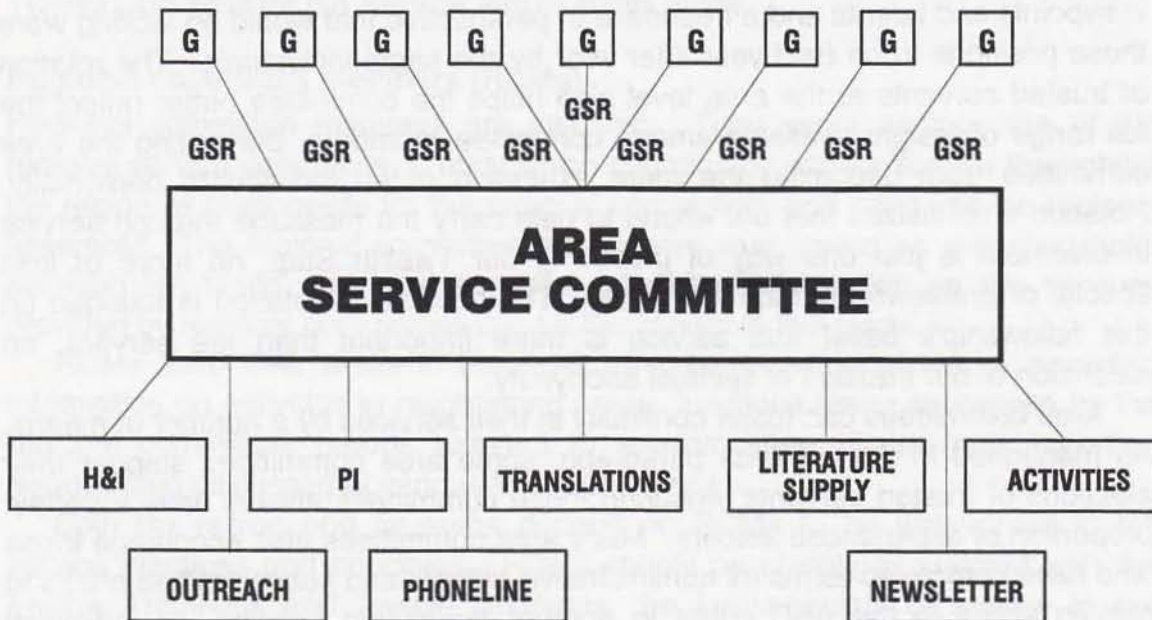

subcommittees, giving them sufficient liberty to serve freely while still maintaining their accountability.

The ASC is responsible not only to develop and maintain subcommittees in each field of service but to coordinate the work of each of those subcommittees with the work of the others. For these reasons, all area committee participants need to become as informed as they can possibly be about subcommittee activities. Area committees devote significant portions of their meetings to reports from subcommittee chairpersons and discussions of subcommittee activities. Handbooks are available from the World Service Office for most of the subcommittees listed below. Specific directions for subcommittees in your area can be found in your log of policy actions and (if applicable) your area guidelines.

Most newly formed area service committees will probably not be able to support the same wide range of subcommittee services as a longer-established committee. Rather than attempt to set up all their subcommittees at once, it's recommended that new area committees take their time. Make sure the responsibilities of new subcommittees are well coordinated with those of existing ones. Bring subcommittees on line one at a time and give a great deal of attention to developing each subcommittee before bringing on another.

Translation

Translation subcommittees perform one of the most basic services possible for an NA community: They ensure that the written NA message is available in the language spoken by local members. Translation subcommittees also assist in translating service-related correspondence and periodicals so that the members of their NA communities can take a fuller part in the life of the worldwide NA Fellowship. If your NA community needs a translation subcommittee but does not yet have one, the World Services Translation Committee will be happy to help you start one. For assistance, contact the translations coordinator at the World Service Office.

Hospitals and institutions

Hospitals and institutions subcommittees conduct panels that carry the NA message to addicts who often have no other way of hearing our message. *Treatment panels* are conducted for patients at addiction treatment centers, mental health facilities, and therapeutic communities. *Correctional panels* are held for inmates at jails, prisons, and forensic hospitals. The *Hospitals and Institutions Handbook*, available from your local H&I subcommittee or by writing the World Service Office, explains more about how to conduct panels, interact with facility administrators, and organize subcommittee work. The amount of work your local H&I subcommittee does will depend on a variety of factors: the number of treatment and correctional facilities in your area, the number of NA members in your area who are interested in H&I service, and the amount of collective experience in H&I work in your NA community.

H&I subcommittee responsibilities sometimes overlap those of the local public information subcommittee. For this reason, we encourage H&I and PI subcommittees to closely cooperate with one another. In some areas, H&I and PI subcommittees regularly send one or two members to each other's meetings to maintain communications, thereby minimizing the potential for conflict in these two key fields of service.

Public information

The general mission of your area public information subcommittee is to inform addicts and others in the community of the availability of recovery in Narcotics Anonymous. Services provided by PI subcommittees vary widely from area to area. The simplest kind of PI project is the production and distribution of fliers throughout the community announcing that NA is available and that more information can be had either by calling the local NA information phonenumber or by attending an NA meeting. As PI subcommittees become better developed, they often conduct public meetings for community members, distribute public service announcements to local radio and television stations, and respond to public media inquiries. Some PI subcommittees develop separate working groups called CPC panels (short for *cooperation with the professional community*) to focus especially on the NA community's relations with local treatment professionals. *A Guide to Public Information*, available from your local PI subcommittee or by writing the World Service Office, provides detailed information on conducting a wide range of projects designed to increase community awareness of Narcotics Anonymous.

Many public information projects serve primarily to encourage people to call the local phonenumber for more information on NA. Because of the close link between PI and phonenumber work, it will often benefit these two subcommittees to cultivate close relationships with one another. Some phonenumber and PI subcommittees make it a standard policy to send members to one another's meetings to better facilitate communication between the two. In some areas, a single subcommittee administers both the phonenumber and NA's public relations program.

Phonenumber

The phonenumber subcommittee maintains a telephone information service for Narcotics Anonymous that helps addicts and others in the community find us easily and quickly. Phonenumber volunteers often serve as the first point of contact between the community-at-large and the NA Fellowship. For this reason, it's vital that careful attention be paid to the work of this subcommittee.

Phonenumber subcommittees in different NA communities organize their work in different ways to meet local needs. In some areas, PI and phonenumber services are operated jointly by a single subcommittee. In smaller communities, the phonenumber may be as simple as a call-forwarding service connecting callers with NA members' home telephones. In the larger metropolitan areas, computerized systems may route incoming calls to the appropriate people and information. For more details on NA phonenumber services, consult *A Guide to Phonenumber Service*, available from your local phonenumber subcommittee or by writing the World Service Office.

Literature supply

The literature supply subcommittee maintains a stock of NA books and pamphlets that can be purchased by local groups at the monthly ASC meeting. In some areas, this subcommittee may consist of only one or two people. In other areas, it may involve as many as half a dozen members who process group orders, monitor stock levels, and reorder materials from the local NA office or the World Service Office. To maintain accountability for all area funds, most areas ask their treasurer to serve as cashier for literature sales. The subcommittee then goes to the treasurer for a check when it has to reorder stock. To help organize the job of processing group orders, tracking inventory, and reordering depleted items, contact the World Service Office for available resources.

Newsletter

Some areas form subcommittees which publish local newsletters listing area and regional events. Some newsletters also run articles on local service activities and members' recovery experiences. Keep in mind that NA newsletters are often read as if they speak for Narcotics Anonymous as a whole, no matter how many disclaimers the newsletter subcommittee prints. That's why we encourage the area committee to take special heed of the Fifth Concept when creating this subcommittee, ensuring the newsletter has a responsible editorial policy. A *Handbook for NA Newsletters*, available from the World Service Office, provides more information on the work of the newsletter subcommittee.

Activities

Dances, picnics, campouts, special speaker meetings--these events are put on by area activities subcommittees. Activities like these can provide a greater sense of community for the local NA Fellowship and produce additional area income. It should always be kept in mind, however, that these functions are designed to enhance NA's primary purpose, not to replace group contributions in funding area services.

A couple of remarks must be made regarding legalities relevant to NA activities. Most activities subcommittees distribute fliers announcing their next event to NA groups in the area. If your subcommittee's flier displays one of the NA logos shown below, a small circled letter "R" (it looks like this: ®) should appear to the right of the logo. This mark shows that the logo is a registered trademark of Narcotics Anonymous worldwide and helps protect the logo from misuse outside the fellowship. For more information, see the bulletin, *Internal Use of NA Intellectual Property*, available from your World Service Office.



**Narcotics
Anonymous®**

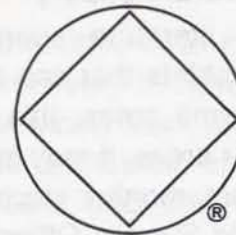

Some activities subcommittees have conducted raffles of one sort or another either as separate fundraising efforts or as parts of another activity. It should be noted that in many US states and in some other countries such raffles are considered gambling and, as such, are illegal. Activities subcommittees should also consider whether raffles, especially cash raffles or lotteries, appeal more to the spirit of self-interest than the spirit of voluntary support implicit in our Seventh Tradition.

Outreach

Outreach subcommittees serve as the outstretched hand of an established NA community to isolated groups and addicts, particularly in large rural areas. By phone, by mail, and by car they make sure that no group and no addict has to go it alone if at all possible. The subcommittee helps keep geographically isolated groups and addicts in touch with the mainstream of the NA Fellowship.

The outreach subcommittee is not the only subcommittee concerned with reaching out to isolated addicts. Sometimes addicts are isolated by factors other than geography: social, economic, and cultural factors, for instance. PI, H&I, and phonline subcommittees can help an area committee focus additional attention on the needs of addicts in our own communities who, for one reason or another, have not found NA accessible. Area service committees and their subcommittees need to do whatever they can to ensure that recovery is available to any addict who seeks it, "regardless of age, race, sexual identity, creed, religion, or lack of religion." Area subcommittees engaging in community outreach activities may find help by contacting the World Service Office.

Meeting lists

Though production of meeting lists does not usually require the creation of a separate subcommittee, most area committees do have one or two people who are responsible for printing meeting schedules on a regular basis. In some areas, this job is handled by one of the committee's administrative officers; in others, by one of the regular subcommittees. Meeting lists show days, times, locations, and other pertinent information for local NA meetings. Meeting schedules often show:

- * whether the meeting is "open" or "closed,"
- * meeting format (Basic Text study, discussion, etc.),
- * location use restrictions (no smoking, etc.),
- * additional needs services (wheelchair accessibility, availability of sign-language interpreter, etc.), and
- * if the meeting is conducted by a specialized group (for instance, a men's, women's, gay, or lesbian group).

At one time or another, most area committees have asked themselves whether a particular meeting should be included on the list. The six points describing an NA group appearing at the beginning of the "Group" chapter in this guide have given most area committees the criteria they've needed in making such decisions.

Meeting lists are often used in conjunction with an area's public relations program. For this reason, we encourage individuals and subcommittees responsible for preparing their area directories to do an especially thorough job. Some of the points to be given extra attention are the accuracy of all listings, the attractiveness and usability of the directory's format, and profanity in the names of meetings being listed.

Area committees are encouraged to send a copy of their meeting schedule to the World Service Office each time the list is updated. Accurate, current lists of meetings help the WSO maintain an up-to-date directory for use in answering questions from around the world.

Ad hoc committees

Sometimes an area committee comes up with a question or special project that does not fit into any existing subcommittee's job description. Perhaps a new piece of NA literature is being developed by world services, for instance, and the area has been asked to gather input on the piece from NA members. Perhaps local members have come up with an idea for a new piece of NA literature that they want to develop a bit before they turn it over to world services. Maybe area groups have begun having difficulty finding new places in which to hold recovery meetings and want the ASC to give extended attention to the matter. Or perhaps the committee feels it's time to develop guidelines for itself. In such cases, the ASC may wish to create an *ad hoc committee* to address the issue.

Ad hoc committees are set up for specific purposes and have limited lives. When they have finished their jobs, they are disbanded. In creating an ad hoc committee, the ASC should clearly specify what the committee's purpose will be, what authority and resources it will be given, and how long it should take to complete the job. Then the area chair may appoint either the entire ad hoc

committee or just a chairperson who will put the ad hoc committee together later. Once the ad hoc committee's work is completed, the committee is dissolved.

AREA COMMITTEE POLICY AND GUIDELINES

One particular word comes to mind regarding area committee policy and guidelines: caution. Some area committees have found themselves so tangled in discussions of service policy and area guidelines--sometimes for months or even years at a time--that they have been sorely hampered in providing the services they were created to deliver in the first place. Here are a few points to consider when entering into policy discussions, points that may keep the confusion to a minimum and the committee squarely on track.

NA's Twelve Concepts for Service can be of great value in untangling knotty policy questions; some consider the concepts tailor-made resources for such discussions. Time invested in studying the Twelve Concepts will repay itself many times over with the clarity they provide. In particular, the concepts speak to the subject of delegated authority. For instance, according to the concepts, when groups want the area committee to perform services on their behalf, they delegate to the committee sufficient authority for the work to get done. And when the area committee elects officers and subcommittee chairs, expecting them to perform particular tasks, the committee also delegates to them the authority to apply their best judgment to the fulfillment of those tasks. Our trusted servants do not govern, but they must be given the trust necessary to effectively serve. These kinds of simple, direct principles can be effectively applied to any number of service-related policy questions.

Another tool that can help an area committee find its way out of "the policy maze" is, simply, a moment's reflection on NA's primary purpose. Unsophisticated as this may seem, it can be quite effective in solving some pretty complex problems. Area committees exist primarily to help make NA groups more effective in carrying the recovery message to the still-suffering addict. Area committee services either:

- * attract addicts to meetings,
- * provide materials for use in meetings,
- * conduct activities designed to strengthen meetings, or
- * perform the administrative functions necessary to do these things.

When caught in a conflict for which there seems to be no resolution, an area committee can stop, call for a moment of silence, and ask itself, "What does this discussion have to do with carrying the message?"

A regularly updated log of area policy actions can be of tremendous help. When confronted with a policy question, area committees can consult it to see what decisions have already been made regarding it. The policy log makes it

unnecessary for area committees to rehash the same question over and over and over again.

Hopefully, enough tools already exist to provide adequate guidance for the work of most area committees: this chapter of *A Guide to Local Services*, the log of area policy actions, the short-form rules of order appearing toward the end of this guide, and the Twelve Concepts for NA Service. Some areas, though, will want to develop their own area guidelines, giving specific directions to their administrative officers and subcommittees. This will be the case particularly for area committees whose subcommittees have substantial responsibilities. It's suggested that area committees give themselves some time to see what kinds of needs for guidelines actually exist in their areas before beginning to draft their own. An area committee equipped with a year or two of entries in the log of policy actions will be in a better position to see what kind of guidelines ought to be developed than an area committee trying to write guidelines during the committee's formation. You can get sample guidelines by writing to the World Service Office. Areas who wish to prepare their own guidelines may wish to appoint an ad hoc committee to adapt those sample guidelines to local needs.

It should be remembered that guidelines, rules of order, logs of policy actions, and similar tools are designed to help keep things simple. If an area committee finds these tools, instead, making things more complicated, time should be scheduled during the sharing session to talk about it.

AREA INVENTORY

Some area committees set aside one day each year for conducting an area service inventory. Why? For much the same reason as NA members do personal inventories: to stop, consider their actions and attitudes, and rededicate themselves to their ideals. The area inventory considers three general topics:

1. How well has the area committee done this year at serving the *groups*, and how can it better serve them in the coming year?
2. How well has the area committee served the larger *community*, and how can the committee better serve the community-at-large?
3. How well has the area committee done at supporting NA's *regional and world services*? How can the area provide better support for these services?

A substantial amount of preparation is required on everyone's part for an effective area inventory. GSRs, officers, and subcommittees must take a fearless, searching look at their work over the last year and come to the inventory session prepared to review their roles on the committee. GSRs should spend time with their groups considering what needs might be addressed by the area committee in the next year and come to the inventory session with ideas in hand. Officers and subcommittees should take the time to look at the make-up of the

larger community in which they live, ask themselves how NA could be more effective in reaching out to that community, and be prepared to share their thoughts with the entire area committee. And perhaps most importantly, all area committee participants should make an extra effort to prepare themselves spiritually to make the most of the area inventory meeting. Materials available from your World Service Office may provide additional help, especially in developing an agenda for your inventory session.

Having conducted an area inventory, many committees will come to the conclusion that certain aspects of their work need to be altered. It should be remembered that there is no one model for area service committees that will be completely appropriate to all areas. A number of factors will affect the kinds of services an area committee offers and the ways in which it offers them: community size, number of meetings, availability of experienced NA members, geography, local laws and customs, and other such considerations. What works in a major metropolitan setting probably won't work at all in a rural community. What will work in any setting is an effort to maintain sensitivity to the needs of the groups and the community. Each area committee will, to a great degree, have to find its own way of effectively providing services to those groups and the larger community of which those groups are a part.

Versatility is called for. Area committees in small or mid-sized communities may see fit to combine the work of some subcommittees, while well-established metropolitan committees might find themselves with a large number of highly specialized subcommittees, each with its own specific focus. Given reasonable consideration, an area committee should not be afraid to configure its services in whatever way it sees fit so that it may help carry the NA message in the most effective way possible.

PARTICIPATION

Participation is a critical factor in delivering services at any level. Lagging subcommittee participation and poor attendance at area committee meetings are problems all area committees must address from time to time, particularly during the annual inventory session. Sometimes the solutions to these problems are simple and quick; more often, they require deliberate, extended attention.

An area that has few GSRs attending committee meetings or lacks support for the work of its subcommittees probably has one or more of the following problems:

- * The area is new,
- * The territory served by the ASC is sparsely populated,
- * Committee meetings are run poorly,

- * The committee, as it is run presently, is too large to allow for GSR participation,
- * Groups and members in the area are not sufficiently informed concerning the role of the area committee and the kind of work being done by its subcommittees,
- * The services provided by the ASC are not meeting the needs of area members or groups, or
- * Members and groups are simply not interested in supporting area services.

Of these, the first two are generally the easiest to address. If a new area is lacking in members available for service, the passage of time alone may well provide a solution; the section later in this chapter, "Creating New Area Committees," discusses this further. And if an area committee serves a sparsely populated territory, there are ways in which it can structure its services to match its circumstances. More on this can be found later in this chapter under the heading, "Area Committees in Rural Communities." You can also write to the World Service Office and ask for any relevant materials they may have on hand.

If one of the remaining problems is the case, an area committee can determine which one it is by sending current committee participants out to the groups, especially those groups who are not sending GSRs, and simply ask them what they think.

When a meeting is poorly run or has too many participants, it is difficult for any but the most outspoken to get a word in edgewise. Sometimes GSRs stop attending their area meeting because it seems like a waste of time. If any of these problems has pushed your area committee off track, there are a couple of options you can try to set your ASC back on course. If your ASC is trying to serve too many groups and committee meetings are so crowded they don't allow most GSRs an opportunity to participate, it may be time to consider dividing the area. The next chapter of this guide talks about the ASC division process from start to finish.

Remember, though, that "too many groups" is a relative term. A poorly run meeting, no matter how many people are taking part in it, always seems "too large." An ASC serving many groups may need nothing more than a leadership tune-up to make its meetings run smoothly, allowing full participation by all committee members. Review of the materials in this guide--especially this chapter, the earlier chapter on the Twelve Concepts, and the short-form rules of order appearing toward the end of this guide--can sharpen an ASC chairperson's focus on the content and process appropriate to area committee meetings, helping the chair lead a more effective meeting. A variety of other books about running meetings, available from many libraries and bookstores, can also be consulted.

If local NA members are unaware of the kind of work being done by the area committee, area officers can be asked to organize a service workshop. Such workshops, creatively conducted, can present groups and members with options for service of which they'd previously been unaware and spark their interest in becoming a part of those services.

If the area committee is not currently providing services that meet the real needs of local members or groups, such a workshop could serve as a combination open forum and brainstorming session. Drawing from the experience and insight of everyone who cares to be involved in the discussion, such a forum could pinpoint inadequacies in current services and develop directions for future services that better address the needs of the local NA community.

Some NA groups will not be interested in taking part in area services, no matter how effective and inviting they might be. These groups may feel that their experienced members have more than enough to do with just supporting their recovery meetings. It's true that NA groups are responsible to support NA services, but they are responsible first to conduct NA meetings. Our tradition of group autonomy gives them the right to decide for themselves whether or not they are able or willing to extend their support to the area committee. No matter what they decide, the area committee has a responsibility to serve all the groups in its service territory, regardless of whether or not a particular group has chosen to participate in the work of the committee.

AREA BUDGETING

A budget helps an area committee be a better manager of the funds it receives. The basic process for developing an area committee budget is pretty simple; for your convenience, a budget worksheet has been included in the *Treasurer's Handbook*, available from your World Service Office. On a quarterly or annual basis, administrative officers and subcommittee chairpersons present their plans for the next work period along with estimates of how much that work will cost. By comparing the projected work plans and expenses with income reports from the last work period, the area committee will have a pretty good idea of how feasible the budget proposal is and can vote to either adopt it or alter it.

Narcotics Anonymous groups directly support area, regional, and world services from money left over after covering their own expenses. Area committees, after setting money aside to cover budgeted expenses, are encouraged to do the same with their surplus funds, sending it on to the other levels of the service structure.

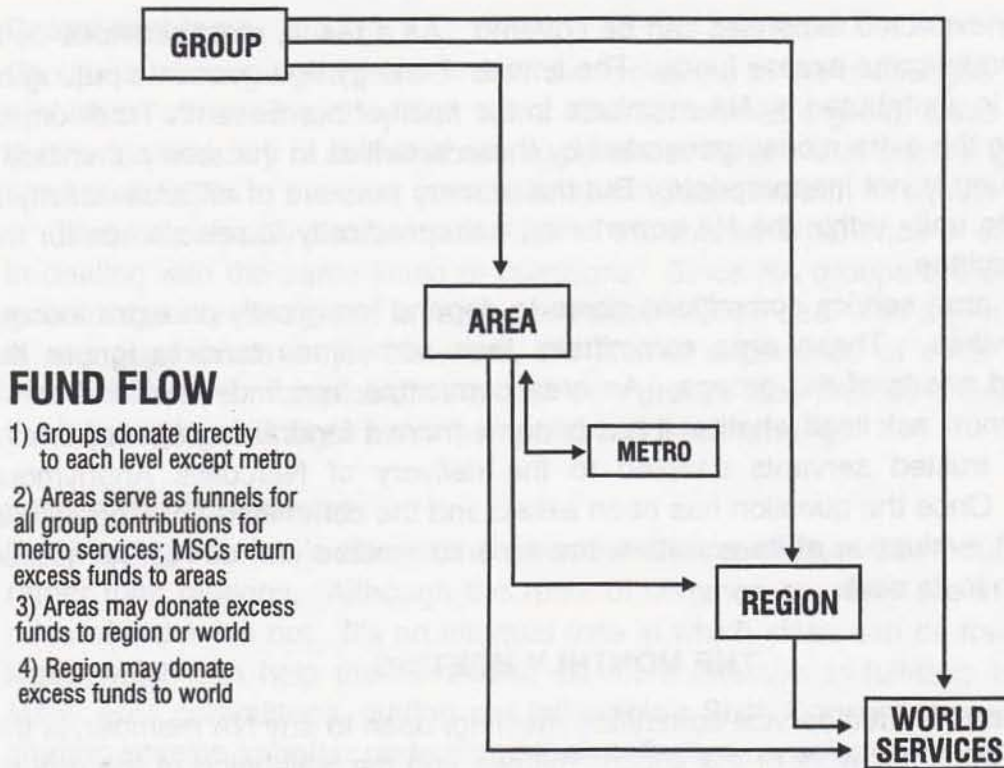

OTHER FUNDING CONSIDERATIONS

Area committees generally assign their treasurers the responsibility of managing all ASC funds. When officers or subcommittee chairpersons need money for a budgeted project, they ask the treasurer to write them a check to be countersigned by another ASC officer. The same general procedure can be applied by area committees that do not develop quarterly or annual budgets, except that specific spending proposals must be presented by officers and subcommittees to the full area committee before funds can be drawn from the treasury. The officer or subcommittee chair turns receipts for their expenses in to the treasurer along with whatever money may be left over from their advance. If the project produces income, that money is also returned to the treasurer for deposit back into the general fund. A single general fund helps ensure that the area committee is able to maintain final responsibility for the activities of its subcommittees. It also eliminates the need for each subcommittee to duplicate the treasurer's job.

Most areas periodically struggle with the question of fundraising versus group contributions for support of their work. Activities subcommittees usually plan to have their projects come out in the black (as opposed to coming out in the red)

so that unexpected expenses can be covered. As a result, most activities do in fact generate some excess funds. The time and energy that goes into putting on activities is contributed by NA members in the spirit of our Seventh Tradition, so depositing the extra money generated by those activities in the area committee's general fund is not inappropriate. But the primary purpose of an area activity is to promote unity within the NA community, not specifically to raise funds for the area committee.

Some area service committees come to depend too greatly on extra income from activities. These area committees then sometimes tend to ignore the expressed needs of the groups. An area committee that finds itself in such a situation must ask itself whether it has become more a fundraising agency than a group of trusted servants devoted to the delivery of Narcotics Anonymous services. Once the question has been asked and the committee has engaged in an honest evaluation of its activities, the area committee can correct its course and return to its work.

THE MONTHLY MEETING

The monthly area service committee meeting, open to any NA member, is the event at which the work of the subcommittees and the well-being of the groups all come into focus. Before the meeting starts, one of the administrative officers gives an orientation to new group service representatives. Then officers, subcommittee chairpersons, and GSRs report on what's happened since the committee met last. The sharing session gives all participants the opportunity to engage in wide-open discussion of group problems and area committee issues raised by the reports. After the sharing session the committee is ready to go straight to business, considering questions about the work of its officers and subcommittees. The sample agenda which appears at the end of this chapter can be used by most area committees as a tool for organizing the monthly meeting. And the short-form rules of order appearing toward the end of this guide can help the business of the committee be processed in an orderly, respectful fashion.

THE SHARING SESSION

The sharing session has two types of agenda: group problems and area committee issues. Agenda items for the sharing session usually come up during reports from group service representatives, administrative officers, and subcommittee chairpersons. After each report is given, anyone on the area committee--including the person who gave the report--can ask the committee chairperson to place a particular subject on the sharing session agenda.

Group problems

Groups are encouraged to seek their own solutions to the challenges they face--and, most of the time, they find them. But sometimes a group faces a problem that is beyond any of its members' experience. When that occurs, groups can send their GSRs to the area committee sharing session with a request for help.

That help usually comes in the form of the shared experience of other groups in dealing with the same kinds of questions. Since NA groups are entirely self-governing, only rarely can an area committee motion deal with a group problem in any appropriate way. However, the shared experience of other committee members with similar problems in their own groups may provide a GSR with just the information or insight his or her group has been lacking.

Area committee issues

The sharing session is also a time when the area committee can focus on issues rather than motions. Although the rules of common courtesy are in place, the rules of order are not. It's an informal time in which ideas can be freely shared, ideas which can help the committee be more effective in fulfilling its purpose. Many area committees, putting our fellowship's Sixth Concept to work, use the sharing session to better understand their collective conscience on area business before making decisions.

The Sixth Concept for Service talks about group conscience as "the spiritual means by which we invite a loving God to influence our decisions," and carefully distinguishes the spiritual discipline of group conscience from the decision-making mechanism. Perhaps nowhere is that distinction more evident than in the sharing session. In the sharing session, committee participants consult their individual consciences--and their Higher Power--on the broad issues at hand, share the insights resulting from that, and together develop a collective direction for the committee. In the business portion of the meeting, those same participants try to express that group conscience in the specific form of motions and votes. But committee motions cannot be an effective expression of the spiritual aims of our fellowship without the free exchange necessary for the development of a group conscience having first occurred. The sharing session is designed specifically to facilitate that occurrence.

Let's say the public information subcommittee's report suggested in general terms the need to be more energetic in reaching out to drug abuse treatment professionals in the area. During the sharing session, a variety of issues pertaining to PI's suggestion can be discussed: What's the difference between "energetic" PI work and outright promotion of NA? To what extent, if any, does cooperation with the professional community border on the endorsement of outside enterprises? And is this where the area wants to spend more money, or

are there other projects more deserving of immediate attention? No motions, no calling of the question, no parliamentary inquiries--just a free exchange of ideas among NA trusted servants producing greater understanding of directions in which area services might head.

The sharing session is the appropriate time for members to exercise NA's Ninth and Tenth Concepts. These concepts remind us that our committees are responsible to listen to all participants' voices with respect and that all members have a right to be heard. Minority opinions on committee business can be expressed freely and clearly in the sharing session. And problems potentially calling for the redress of a personal grievance on the part of a committee member can be aired in an open, supportive atmosphere.

AREA COMMITTEES IN RURAL COMMUNITIES

In many rural towns, even after many years of existence, only one or two NA groups may have formed. The distances between such towns and the relatively few members available to serve may make it impractical for a rural area committee to conduct any common services for its groups. It's more usual in rural areas for the individual groups themselves to administer what direct services there are in each community. When the group has its business meeting, members discuss not only the group's recovery meeting but their collective efforts to facilitate Twelfth Step work in the community. The group may get a post office box to make it easier for people in the community to contact NA. The group might even open its own telephone line with an answering machine offering recorded information about the local NA meeting. One member might take responsibility for ordering the group's NA literature directly from the World Service Office. The whole group may decide to get together one Saturday and put NA fliers up around town. Regular group contacts with local magistrates, social workers, physicians or health clinics, school counsellors, and clergy can help NA's friends guide newcomers to the group's meeting.

In some rural districts, groups join forces to form cooperative councils, called "co-ops" for short. Representatives of groups within 50 kilometers (31 miles) of one another in one corner of the area, for instance, might gather each month to coordinate their H&I panels, community contact programs, social activities, and common phonenumber. If GSR travel to area committee meetings is burdensome--say, if the ASC meets more than 100 kilometers (62 miles) away--they might even select one of their members to represent the co-op each month on a rotating basis.

The following diagram shows such an area. The four northwestern groups have formed Co-op #1 to run a phonenumber and coordinate a weekly H&I panel at the nearby county work farm. Co-op #1's four GSRs take turns attending the

RURAL AREA WITH CO-OPs

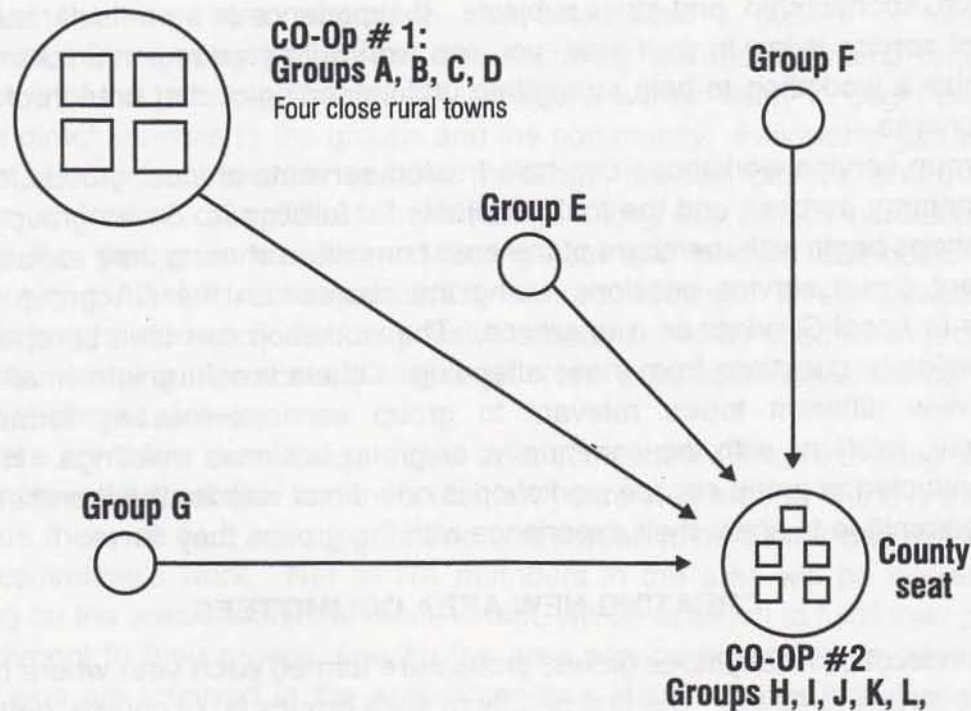

area committee's monthly meetings. The five county seat groups in the southeast have formed Co-op #2 to administer NA services in that small city. All five GSRs from Co-op #2 attend the ASC meetings, which they host.

Rural area committee meetings often become mostly a sharing session. Group service representatives discuss their groups' progress with one another and provide solutions to each other's problems. Some rural areas conduct joint activities--dances, speaker meetings, and workshops--to promote unity and enhance their groups' effectiveness. Many rural committees appoint individual members as area resource contacts for particular fields of service whose job it is to gather information on H&I, PI, or phonedines for other groups to use. Rural area committee operations are simple, but the strength gathered from the unity they provide is just as important as it is in a metropolitan setting.

LEARNING DAYS, WORKSHOPS

Learning days and workshops sponsored by area subcommittees are valuable tools for increasing area members' awareness of the work conducted by the area committee. For most fields of service--H&I, PI, phonedines, etc.--complete descriptions of how to conduct local learning days and workshops are

provided in the respective service handbooks. Many area committees also conduct topical workshops on the Twelve Traditions and Twelve Concepts for NA Service, sponsorship, and other subjects. If experience in a particular subject or field of service is low in your area, you can work with your regional committee to organize a workshop to help strengthen understanding of that branch of service in your area.

Group service workshops can help trusted servants of local groups focus on their primary purpose and the tools available for fulfilling it. Some group service workshops begin with members of the area committee sharing their experience in different group service positions, using the chapter on the NA group from *A Guide to Local Services* as a reference. The workshop can then be opened for discussion or questions from those attending. Others break up into small groups to review different topics relevant to group services--meeting formats, for example, relations with the community, or group business meetings. However it's conducted, a group service workshop is one direct way for the members of an area committee to share their experience with the groups they serve.

CREATING NEW AREA COMMITTEES

As Narcotics Anonymous grows, groups are formed each year where no area service structure exists. The first priority of such groups is, of course, getting the group on its feet and developing stable meetings. In larger communities, a stable group often sprouts new groups and new meetings. At some point, those groups begin to think about creating a common committee for themselves--what we call an area service committee--to serve their mutual needs and make it easier for them to pool their efforts in reaching out to the community. Groups considering the formation of a new area committee can tap the experience of their regional service committee or, if no regional service committee exists, the World Service Office.

Some new area committees try to start up all at once with a full complement of administrative officers and subcommittees, monthly dances, a convention, and a local service center. Area committees which try to do this may sorely disappoint themselves. Remember: first things first.

Area committees are formed, first, to strengthen the groups that create them. Before an area committee can start serving the community, the groups which make up that area must be on solid footing. An area committee just beginning its service journey may exist primarily as an environment in which groups can share their strengths and solutions with one another.

The new area committee might also consider focusing a considerable amount of its attention on the study of NA's Twelve Traditions and Twelve Concepts for Service. An area committee that takes care to establish a firm foundation before

attempting to erect even a simple service structure will not be likely to regret the time taken in doing so.

Once the new area committee has established a pattern of facilitating communication among the groups and nurturing an understanding among its members of the principles behind NA service, it will be ready to begin providing simple direct services to the groups and the community. Fellowship gatherings--learning forums, cooperative speaker meetings, dances, picnics, and the like--require a minimum of organization yet can go a long way toward increasing unity among the groups in the area. Meeting lists and posters distributed in the community can help direct more addicts to more meetings. Direct services don't have to be grand, complicated, expensive enterprises to be effective in promoting unity and carrying the recovery message. New area committees will do well to start with simple projects.

There are a few more things a new area committee will want to keep in mind, both in its initial formation and in its first few years of operation. First is the need to share the workload, ensuring that no one person is burdened with most of the area committee's work. Not all NA members in the area will be interested in serving on the area committee; most, in fact, will be satisfied to fulfill their primary commitment to their groups, leaving the area service committee to others. But those who are involved in the area committee should see to it that committee work is divided evenly among them. A committee supported primarily by one member is too vulnerable to collapse should that lone individual begin to suffer from "trusted servant burnout" or become unavailable for some other reason. If only a few members are involved in an area committee, they should consider keeping their workload light rather than overreaching their capacity.

A second consideration for new area committees is the idea of making a commitment to meet regularly--once a month, if possible. Most new committees will be occupying themselves primarily with developing means of supporting member-groups and the study of NA traditions and concepts of service. Those agenda items require regular, concentrated attention as the area committee establishes its foundation. A commitment to meet regularly, right from the start, helps keep that need in the foreground.

Finally, the new area committee will greatly benefit from continued contact with its regional service committee, with neighboring area committees, and in some cases with groups and service committees in neighboring countries. Just as individual addicts don't often make it on their own, area committees can greatly benefit from the shared experience, strength, and hope of those who've gone before them. None of us has to do it alone--not anymore.

SAMPLE AREA COMMITTEE AGENDA

The typical agenda for an area committee meeting often looks something like this. The committee fills it in each month with more specific topics under each heading.

CALL TO ORDER

- * reading of the Serenity Prayer
- * reading of the Twelve Traditions and/or Twelve Concepts for NA Service
- * roll call
- * recognition of new groups
- * approval of last month's minutes (additions or corrections are made)

REPORTS

- * administrative officers' reports
- * group reports
- * special (ad hoc) committee reports
- * standing subcommittee reports

SHARING SESSION

General discussion of group concerns and issues raised by reports.

OLD BUSINESS

Motions are in order regarding business left over from previous meetings. (Some areas also conduct their elections of trusted servants during this portion of the agenda.)

NEW BUSINESS

Motions are in order regarding business that is new to this committee.

ANNOUNCEMENTS

ADJOURNMENT

DIVIDING AREA SERVICE COMMITTEES

Locally, most area service committees serve dual functions, offering both group support and direct service administration. A small area committee, while providing a forum in which groups can share their experience with one another, often has difficulty administering direct NA services. An especially large committee, on the other hand, may have plenty of money and manpower for direct service administration but be too large to accommodate the kind of sharing that its groups need to support one another.

Areas grow and change. As time passes, some area committees find themselves with so many GSRs attending that it's almost impossible to conduct orderly monthly meetings. Others start to ask whether an area committee that serves many towns might not be more effective if broken up into a number of committees separately serving those towns. Still others experience internal conflicts and wonder whether it wouldn't be easier just to separate the camps into their own area service committees. Regardless of where the question comes from, it's important that the answer follow only on careful consideration of the group conscience of the entire area. There's much to examine and many questions to answer in dividing an area.

Many areas begin considering a division when they reach a certain size. But how big is a "big" area, and how small is "small"? Areas range in size from five to fifty or more groups. Yet size often has less to do with how well an area works than effective leadership, commitment to principles, and the consistent involvement of area groups. There is no magic number that should trigger an area division; the only appropriate trigger is function, not form.

If your area is discussing the possibility of a division, we suggest you conduct an area inventory and review the criteria described in coming sections of this chapter to carefully examine your area's services. If you discover problems in your ASC such as those described under the inventory heading in the previous chapter, see if you can solve them by some means other than the division of your area. If, after all this, you still believe the interests of the NA community and the community-at-large can best be served by dividing your area, you can proceed with confidence.

Before getting into the mechanics of division, there's one more thing we must emphasize: Your groups aren't getting a divorce! It's the service apparatus you're dividing, not the fellowship. Even as you plan to divide your area, we encourage you to also take steps to maintain the unity of the NA Fellowship in your community. By scheduling regular joint speaker meetings, social events, and workshops for all the groups formerly served by the original ASC, you can substantially ease the trauma of an area division.

HOW TO DIVIDE

Like any organization, an NA area committee has responsibilities, assets, and liabilities. When a portion of the groups served by an ASC unilaterally decides to pull out and form its own area committee, it may leave the parent committee impaired in its ability to serve the remaining groups. That's why, when an ASC is ready to divide, we encourage the entire area to participate in the division process. Open your lines of communication, work out the issues, recognize the problems, resolve whatever disagreements may arise, and then take an active part in implementing the program developed by your area--in other words, cooperate and surrender!

The territory, assets, and liabilities of the original area committee should be carefully inventoried. Then, by mutual agreement, those responsibilities should be equitably divided among the new areas before the division is actually affected. Such a transition eliminates the potential for disruption of vital NA services to the groups and the community, assuring that we continue to fulfill our primary purpose.

Area boundaries

Clear area boundaries help each ASC understand its responsibilities and assure that NA services are delivered consistently. If a call for service comes from a particular location, there is no question whose job it is to answer that call. And when ASC subcommittees develop work plans for service within their territory, they can be sure they have fulfilled all their responsibilities.

The simplest, most natural divisions of service territory are based on already existing geographic, political, or other functional boundaries. A very large area, for example, might create an ASC for each county within its former domain. A city already divided into wards could develop area committees within each ward. And a heavily populated valley split by a river or major thoroughfare could initiate new area committees on either side of the water or roadway. Brainstorm the possibilities, discuss them among yourselves, and do what seems best for the members in your area.

When creating new area boundaries, we should consider the resources contained in each territory. Ideally, each new area will have about the same number of groups. So that all the areas have access to the service experience they need, none of the new areas should have a predominance of the trusted servants from the old area. Consideration should also be given to the financial base from which each new area will have to build. In some areas, most ASC contributions come from groups in one or two districts. If at all possible--and it may not be possible--try to divide those districts equitably among the new areas.

There is one very sensitive issue to examine when defining new area boundaries: segregation. In many places, geographic and political boundaries serve to segregate racial, ethnic, cultural, religious, and economic communities from one another. Creating area committee boundaries that are based on such divisions can have the effect of isolating a minority within the NA community from the resources of the majority population. These divisions can engender or aggravate antagonisms, threaten our common welfare, and fracture the unity on which our personal recovery depends. Areas deliberately created to include members from diverse backgrounds can enhance NA unity and emphasize the appeal of our message to all addicts regardless of "age, race, sexual identity, creed, religion, or lack of religion."

On the other hand, area boundaries drawn along cultural lines can give minority groups a forum in which their cultural values are honored and their common needs are squarely addressed without dilution or compromise. If your area is considering a division plan which has the effect of segregating minorities within the NA community, we encourage you to carefully examine all the pros and cons before proceeding, paying special attention to the express wishes of minority groups in your community. If you decide to proceed with such a division, we also encourage you to plan frequent joint activities for all the NA members and groups served by the original ASC. Joint dances, speaker meetings, picnics, and similar activities remind us that, though our services may be dividing into a number of area committees, our fellowship remains one.

Functional analysis

Once boundaries have been defined for the new area committees, the next step is a functional analysis of the old area committee's services. Has the ASC maintained a phonenumber? Has a meeting list been published? What kinds of activities has the public information subcommittee coordinated, and where? How many facilities has the H&I subcommittee run panels in, and how frequently? For each subcommittee, you could list out each and every function separately, covering each of the following factors:

Service: Describe the service (maintaining a phonenumber, running a particular H&I panel, participating in a specific annual PI event, publishing a group directory, etc.) as completely as possible.

Location: Where is this operation carried out? What territory does it cover?

Frequency: How often does this function need to be performed?

Time: How much time does it take to perform this duty?

Cost: What expenses are involved in fulfilling this service?

Personnel: How many people are required to complete this mission? What particular jobs are the various participants responsible for?

After the old area's responsibilities have been analyzed, the functions can be divided up among the projected new areas. Based on these analyses, subcommittees can be designated for each new ASC, work plans and budgets can be developed, and suitable guidelines can be created before the old area dissolves and the new areas assume its responsibilities.

TO METRO...

As we noted earlier, most area committees perform double duty, serving as both direct service administrators and group support facilitators. In dividing a larger city¹ that has been served by a single area committee, your NA community may want to consider maintaining the administration of its active service subcommittees under a single body: the *metropolitan services committee*. This leaves the new area committees free to serve as forums in which their constituent groups can share with and support one another.

Administering citywide NA services through a metro committee has a number of potential advantages, among them:

- * Effective subcommittee teams are not split up. This allows NA to make the best use of its limited volunteer leadership base without diminishing services delivered in any of the new areas.
- * The expenses involved in administering separate H&I, PI, phonenumber, and office services in each of the city's areas are consolidated, eliminating duplicate costs for the same administrative functions.
- * Because primary oversight of working subcommittees occurs in only one place, the metro committee, rather than in all the ASCs, the NA service community requires less time for supervising the subcommittee bureaucracy and has more time to focus directly on the needs and challenges of NA groups.

The next chapter is devoted to the consideration of metropolitan services committee operations.

...OR NOT TO METRO?

Some multi-area cities will not wish to form a metropolitan services committee, instead administering direct services separately in each constituent ASC. In the process of splitting a large metropolitan area committee into multiple ASCs, how can the NA community decide whether or not it will form a metro committee in addition to the new areas? The primary consideration must be

¹ For the sake of convenience, we will be using the word "city" (singular) to refer to any major metropolitan area and its environs, even though most such metropolitan areas are actually composed of a number of adjacent cities and unincorporated districts and sometimes cross both county and state lines. Examples of such "cities" include New York, Los Angeles, Chicago, São Paulo, Mexico City, Tokyo, and London.

function, not form. The existence of a chapter on metro committees in *A Guide to Local Services* is not, of itself, sufficient reason for you to create a metro committee in your city. A metropolitan services committee should be created only if it will truly serve the needs of Narcotics Anonymous in your locale.

Metro committees are usually formed in larger metropolitan communities served by more than one ASC. If your large area is dividing into a number of smaller areas that will serve separate cities, you will probably have no need to

AREA SHARED SERVICES COMMITTEE

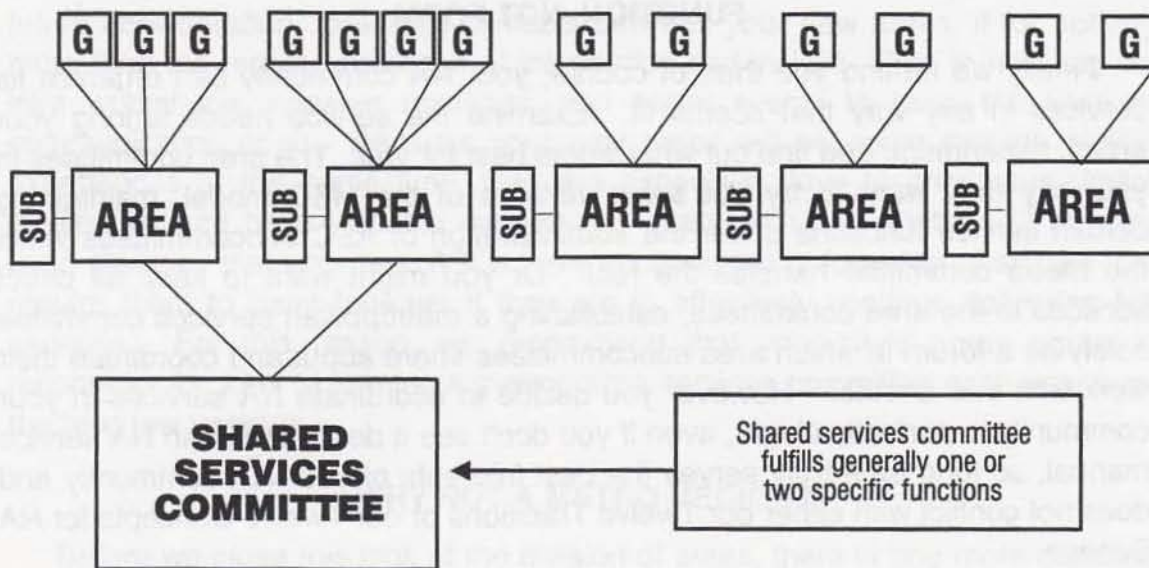

form a metro committee. Each of the new area committees can administer direct services in their own communities without creating conflicts or redundancies.

If the need for shared services among the various ASCs in your city is limited to only one or two fields of service--say, H&I coordination with county jail administration or PI media coordination--you might establish shared services committees to focus on those fields only. However, if the need for shared services covers more than one or two fields, you will probably want to establish an MSC that coordinates services through a subcommittee system. Otherwise, with all the ASCs having to become directly involved in three or four separate

shared services committees, there may well be too much bureaucracy, confusion, and controversy to make it worthwhile. The idea behind the decision to create or not create a metro services committee is to keep it simple, based on local needs.

If the need to coordinate shared services is not ongoing but limited to one-time events, such as joint workshops or social activities, the areas in your NA community don't need to set up a permanent committee to organize these affairs. Simple, mutually acceptable arrangements to handle that one combined workshop or social activity can be made each time one is planned without creating yet another service body. If the need is ongoing, however--such as for a monthly combined-areas speaker meeting--your community will probably want to establish a permanent shared services committee that coordinates the event.

FUNCTION, NOT FORM

Finally we remind you that, of course, your NA community can organize its services in any way that seems fit. Examine the service needs among your areas, experiment, and find out what works best for you. The area committees in your city may want to try out some variants of the MSC model, maintaining certain service functions under the administration of ASC subcommittees while the metro committee handles the rest. Or you might want to keep all direct services in the area committees, establishing a metropolitan services committee solely as a forum in which area subcommittees share about and coordinate their work with one another. However you decide to coordinate NA services in your community is perfectly alright, even if you don't see it described in an NA service manual, so long as it truly serves the best interests of your NA community and does not conflict with either our Twelve Traditions or our Twelve Concepts for NA Service.

MULTIPLE AREAS

If the area committee serving your city is dividing and you've decided not to form a metropolitan services committee, there are three additional subjects you should consider. First, when you define boundaries for the new areas and analyze and divide service responsibilities among them, keep a sharp lookout for places where future territorial conflicts may arise. In an ideal world, such conflicts would not occur. However, our world is far from ideal, and conflicts do raise their head from time to time. Since we can't avoid such conflicts altogether, the best we can do is be prepared for them. In the process of dividing your city's ASC, build into each new area's policies a procedure for resolving conflicts with other areas. You may not be able to sidestep such conflicts, but you can prepare to deal effectively with them.

Second, examine your division plan for any potential weak spots in any of the new areas you are creating. For example, does Area 2 have very few people involved in H&I work right now, but a number of correctional and treatment facilities? Is no one in Area 4 involved in the current public information subcommittee? Will it be burdensome for all the new areas to maintain their own separate phonelines? Potential weaknesses like these may not convince you to form a metro committee at this time. However, they should alert you to the possibility that the new areas in your city may require each other's help in the future. Try to build into your division plan means by which your city's areas can cooperate with one another so that NA services can continue to be delivered to those who need them.

Finally, even if your area committee is dividing without forming a metro committee at this time, we encourage you to leave the MSC option open for future consideration. Maintain contacts between your new areas, if for nothing more than the regular exchange of information and insight. Plan to hold regular joint workshops, speaker meetings, and social events to keep the lines of communication open. Because your new areas will be going through similar experiences at the same time, they are especially likely to encounter similar challenges and have valuable expertise to share with one another. You may even discover that your new ASCs have encountered unforeseen obstacles that require them to band together if they are to effectively continue delivering NA services. For this reason, we recommend that your city's areas agree to reconsider the idea of forming a metropolitan services committee each year over the next few years.

WHY NOT A METRO REGION?

Before we close this look at the division of areas, there is one more question that must be addressed: In dividing a very large ASC serving a major city, why not form a metropolitan region rather than an MSC?

First, there's the nature of the NA region itself to consider. Our regional committees serve as forums for resource development for their member-areas, not primarily as direct service providers. Just as growing area committees often find the responsibilities of service administration forcing them to downplay their group support function, so the regional committee that is too occupied with administering its own direct services will have difficulty focusing on area resource development. The region that does only one thing stands a good chance of doing it well. The metro region, trying to do many things at the same time, may find it difficult to do any of them well.

Second, there's the wide variety of shared ASC service experiences exchanged at the regional level to consider. In the region serving a broad

territory, rural areas, small-town areas, and city areas gather to share many different kinds of insight gathered from their widely varied circumstances. This variety is the greatest strength of the most successful regional committees, offering new and different service perspectives to every single member-area. Areas joining a metropolitan region would limit their access only to the experience of those areas having virtually identical backgrounds, challenges, and insights. Such limited experience may not be sufficient to stimulate the innovation of new ideas for new services and new answers to new problems.

Third, consider that regions serving both rural and metropolitan communities often depend on their larger areas for a major percentage of their operating income. Creating a metro region could pull the financial rug out from under the existing region's feet, leaving it flat on its fiscal back and unable to serve. This could seriously affect the other areas, even NA as a whole.

We encourage multi-area NA communities with a need to coordinate a variety of common services citywide to form metropolitan services committees rather than metropolitan regions. That way, citywide services are handled responsibly and the wider region is left solvent and intact, free to focus on resource development for all its member-areas and able to offer a variety of experience, strength, and hope to ASCs throughout the region.

THE METROPOLITAN SERVICES COMMITTEE

A metropolitan services committee administers a single set of NA subcommittees in a city that has more than one ASC. With direct services consolidated citywide by the MSC, the community's area committees are left free to facilitate group support.

For the sake of convenience, we will be using the word "city" (singular) to refer to any major metropolitan area and its environs, even though most such metropolitan areas are actually composed of a number of adjacent cities and unincorporated districts and sometimes cross both county and state lines. Examples of such "cities" include New York, Los Angeles, Chicago, São Paulo, Mexico City, Tokyo, and London.

In the previous chapter, we examined the division of a city's ASC into multiple areas and some of the criteria that could lead to creation of a metropolitan services committee. Here, before getting into how the metro system works, we want to look at some of the reasons why multiple areas in the same city might want to consolidate their services by creating a metro committee and the process whereby they can do that.

WHY CONSOLIDATE?

Why would multiple areas in a large community want to form a metropolitan services committee? There are three primary reasons. First, the consolidation of services citywide can help the NA community facilitate subcommittee activity more efficiently. Rather than paying the administrative costs associated with, say, five separate sets of area subcommittees, only one set of metro subcommittees must be funded. The overall time and energy spent supervising multiple sets of subcommittees can be cut substantially with only one set of subcommittees to guide. And it's easier to find the people needed to make a single set of subcommittees work, even if those subcommittees serve larger territories, than it is to staff three or four times that number of subcommittees.

Second, the consolidation of metro services can make it easier for members, groups, and the community-at-large to identify and locate NA resources in the city. A single phoneline is easier to run and costs less than multiple phonelines in the same city, and provides a simpler way for people anywhere in town to contact Narcotics Anonymous. Contacts with jails, institutions, and other organizations that are run on a citywide basis can be coordinated on the same basis, significantly increasing the effectiveness of H&I communications. By providing a single source for public information about NA, anyone anywhere in the community can easily find out about our program. And a single NA meeting

list for the entire city is usually more useful than half a dozen lists covering separate districts.

Third, consolidation of a city's NA services can help the regional service committee work better. In the absence of metro committees, some RSCs have tried to fill the gap, providing consolidated meeting lists, phonelines, H&I and PI services, even literature sales outlets for cities with multiple areas. Though well intended, such direct services have brought these regions' energies to bear on only a fraction of their member-areas. This has left other areas--and underdeveloped communities in particular--without the benefit of the service resource development work that regional committees do best. When ASCs in the same city consolidate and manage metro services themselves, they leave the regional committee free to do what it does most effectively, and to do it for all the region's areas.

Finally, a reminder: If the areas in your city have no particular need to consolidate all their services, but only wish to combine resources in one or two fields, there is no reason why they should form a full-blown metropolitan services committee. Some of the ways to combine limited service forces without creating an MSC are described in the sections entitled "Or Not To Metro" and "Function, Not Form" appearing in the previous chapter of this guide. If your NA community could be served more effectively by a metro committee then, by all means, create one; if you feel something simpler would serve your purposes, then try that. You need no one's permission to be creative, to experiment, to develop original methods for effectively administering local services as your NA community sees fit.

CONSOLIDATION PROCESS

Imagine that the ASCs in your city have decided that they want to consolidate services by creating a metro committee. How do they go about combining two, or five, or nine sets of subcommittees into a single, smooth-working service enterprise? The considerations that go into the consolidation process are very similar to those involved in dividing an ASC that serves one entire city, described in the previous chapter, only from the opposite end.

1. Inventory current services and resources in the affected areas.
2. Then, examine the need for services throughout the community.
3. Finally, put the resources and needs together in a metro services program.

If all these things are taken care of prior to activation of the MSC, the transition to consolidated services will go as smoothly as possible.

Inventory of services and resources

The inventory of current NA services and resources is probably the easiest phase of consolidation, because it is very concrete. For all the ASCs interested in taking part in the metro committee, gather:

- * ASC bylaws, policy logs, and/or guidelines.
- * Guidelines for all subcommittees.
- * A list of all current projects and commitments.
- * A list of past achievements.
- * A personnel roster listing the ASC officers, subcommittee chairpersons, subcommittee members and responsibilities, and GSRs.
- * Budgets for all area activities.

Analysis of service needs

The consolidation process offers your service community a unique opportunity. While examining and reorganizing your NA services, you can also take a comprehensive look at your city and tailor your service efforts to carry our message with maximum impact.

For this analysis, you may wish to hold a conference of the administrative officers and subcommittee chairpersons from each of the areas joining the MSC. Examine your city and your NA community, as they are, and develop a sense of your city's real service needs:

WHAT TO STUDY

1. Where do your city's NA groups meet--and where do they *not* meet?
2. What are the districts in your city like--geography, population density, political inclination, economic stability, ethnicity, and religious orientation?

WHY TO STUDY IT

1. If there are any blank spaces in the city's recovery map, the metro may want to consider developing outreach services to help new groups start up in those locales.
2. To make PI and H&I efforts effective, we must understand our communities and the people who live in them and act accordingly. An approach that works well in one neighborhood may fail dismally in another.

3. What kinds of government, religious, media, and civic institutions exist in your city? What do they do? Where are these institutions headquartered? How are they organized? What geographic territories do they serve? Institutions to consider include jails, courts, social and psychiatric services, houses of worship, newspapers, magazines, radio and TV stations, cable television outlets, schools, service organizations, and medical and treatment facilities.

3. Many of our contacts with addicts and the community-at-large come through our interactions with city institutions. To map effective PI and H&I strategies, we must thoroughly understand the institutional fabric of our communities.

Such an analysis can help you identify the kinds of NA services your metro committee might wish to put in place to meet the needs of NA groups citywide, help new groups establish themselves, reach out to the addict who still suffers in the community, and inform members of the community-at-large about our fellowship.

The metro plan

After current area resources have been inventoried and the NA service needs of the entire community have been analyzed, the time comes to put the two together in the new plan for metro services. What kinds of subcommittees should be organized to meet the NA service needs in your city? And what kinds of service resources exist among the areas joining in the MSC consolidation process? For each metro subcommittee to be created, develop:

- * *Guidelines*, drawing as much as possible from the guidelines that area members are already familiar with.
- * *Goals*, specific performance targets, ranked in order of their priority.
- * *Work plans*, step-by-step descriptions of how these performance targets will be met, including timetables.
- * *Budgets*, linked to prioritized goals and work plans, showing how much money the NA community will need to invest in order to have its services fulfilled.
- * *Personnel rosters*, combining the lists of members currently involved in the various subcommittees in each metro area.

Don't forget to develop basic guidelines for the metro committee itself. Also compile a budget for MSC administrative expenses that covers committee

meeting hall rental fees, costs for duplicating and mailing metro committee minutes, etc.

New focus for ASCs

Once a consolidated service program for the MSC itself has been developed, it may be helpful to square away a few internal matters for the area committees that will be proceeding on a new basis once the metro commences full service operations. What territory will each ASC serve? How many groups meet in each area? What kind of budget will each ASC need for its own operations, and how much money will the MSC need from the areas?

Fellowship review

The last step before implementing your metro consolidation plan, of course, is fellowship review. Send the plan out to all the groups in the areas to be served by the new MSC--or, if possible, hold a workshop or series of workshop to gather input directly from members. Once group comments have been received, considered, and factored into the plan, it should be put out one more time for approval by the area committees that plan to join in creating the metropolitan services committee. Once the plan is approved, ASCs can begin focusing the majority of their energy on the facilitation of group support, while the MSC coordinates consolidated direct NA services throughout the community.

Process reminders

Before leaving this discussion of the consolidation process, here are three things to keep in mind throughout your planning activities:

1. Only areas that wish to be served by the metro committee should take part in the consolidation of citywide services.
2. Keep the regional service committee fully apprised at each step of your consolidation process. Good communications will ensure the support of other areas in the region for the development of your metro committee and keep down the "jitters" in areas not directly involved in or affected by consolidation of services in your city. If you get stuck in the consolidation process, their informed suggestions may help you get unstuck.
3. You are encouraged to contact the World Service Office at any time for additional information on MSC formation, including the addresses of other areas and metro committees that have dealt with consolidation.

ASCs IN THE METRO ENVIRONMENT

In the previous chapter, we talked about the division of areas. Here, we've examined the consolidation of area services. But once a metropolitan services

committee has been established, what do the area committees look like? How do the areas and the metro relate to one another? And what do the ASCs do after responsibility for direct services is consolidated under the MSC umbrella?

ASC responsibilities

ASC responsibilities in the metro environment are very simple. First, such an ASC provides a place and format that facilitates the sharing of group experience, strength, and hope among GSRs. Second, the ASC usually provides means for groups to purchase NA literature. Third, the ASC continues to communicate directly with its regional service committee through its RCMs, helping to provide guidance to the RSC from the area's groups. Fourth, the area committee directly links its groups to the metropolitan services committee in its community. And fifth, since groups support local services with direct contributions to their area committees, the ASC is responsible to fund the metro committee that administers the community's consolidated local services.

Communications

As our Eighth Concept reminds us, "Our service structure depends on the integrity and effectiveness of our communications." This concept is especially critical to the relationship between a metro committee and its member-areas. The MSC manages citywide services on behalf of all groups in the community, yet the groups do not themselves send either representatives or funds directly to the metro committee; each metro group has delegated that responsibility to the ASC to which it belongs. Therefore, full information about metro projects, including the money and personnel needed for each, must be communicated to the groups through the metro's area committees. Likewise, information about group needs and concerns regarding citywide services must be communicated through the ASCs to the metro committee. Regular communication between the metro and area committees helps maintain the MSC's accountability to the NA community, assuring that the consolidated service authority that's been delegated to the metro committee is being carried out responsibly. Good communication also gives the groups the information they need to make informed decisions about how to disburse the funds with which they support the service structure.

ASC participants

An area committee served by an MSC needs only a minimum of structure to fulfill its functions. Because a metro ASC has no subcommittees of its own and scant administrative responsibilities, it can be composed primarily of group service

representatives. An ASC will need to elect a chairperson, secretary, treasurer, and literature distribution person for itself.

The area committee also chooses two regional committee members (RCMs) to serve on its behalf. The RCM's duties are described in the earlier chapter on full-service area committees. RCMs need not be chosen from among current group service representatives. If any GSRs are elected to serve as RCMs, we recommend that they resign from their group positions. The weight of their responsibilities as regional committee members will be plenty for them to bear without also continuing to serve as GSRs.

Metro ASCs have one service position to fill that other area committees don't: the metro committee member (MCM). The MCM serves a function on the area's behalf at the metropolitan services committee similar to that fulfilled by the GSR at a full-service area committee, described in earlier chapters of this guide, with one key exception: Unlike GSRs, the MCM does not participate in regional assemblies. As the name suggests, metro committee members are full working members of the MSC, serving in their area's interests as well as the best interests of the entire metropolitan NA community and providing for communications between the ASC and the MSC. The number of MCMs your area committee must choose depends on the total number of areas participating in your metro committee--the fewer the areas involved, the more metro committee members each one will need to contribute for the MSC to operate effectively. As with the RCM position, MCMs need not be chosen from among the group service representatives, and those GSRs chosen to serve as metro committee members should resign their group positions to keep from becoming overburdened.

ASC funding needs

The direct financial needs of an area committee served by an MSC, in comparison to those of a full-service ASC, are relatively small. A hall large enough to comfortably hold the area's GSRs must be rented. Literature must be stocked for purchase by the groups. Minutes of ASC meetings must be copied and mailed to group representatives. Aside from these, there are few other metro ASC expenses, if any.

However, each ASC served by a metro committee receives all the contributions intended by its groups to be used in administering local NA services. If a metropolitan services consolidation plan is to be effective, the member-areas must not hold onto any more money than that which is absolutely necessary to pay their own minimal expenses. Metro areas should work especially closely with their MSCs to ensure that sufficient funds are being collected and passed along to the metro committee to support direct services in

the community. Any excess MSC funds should periodically be divided up and returned to the areas.

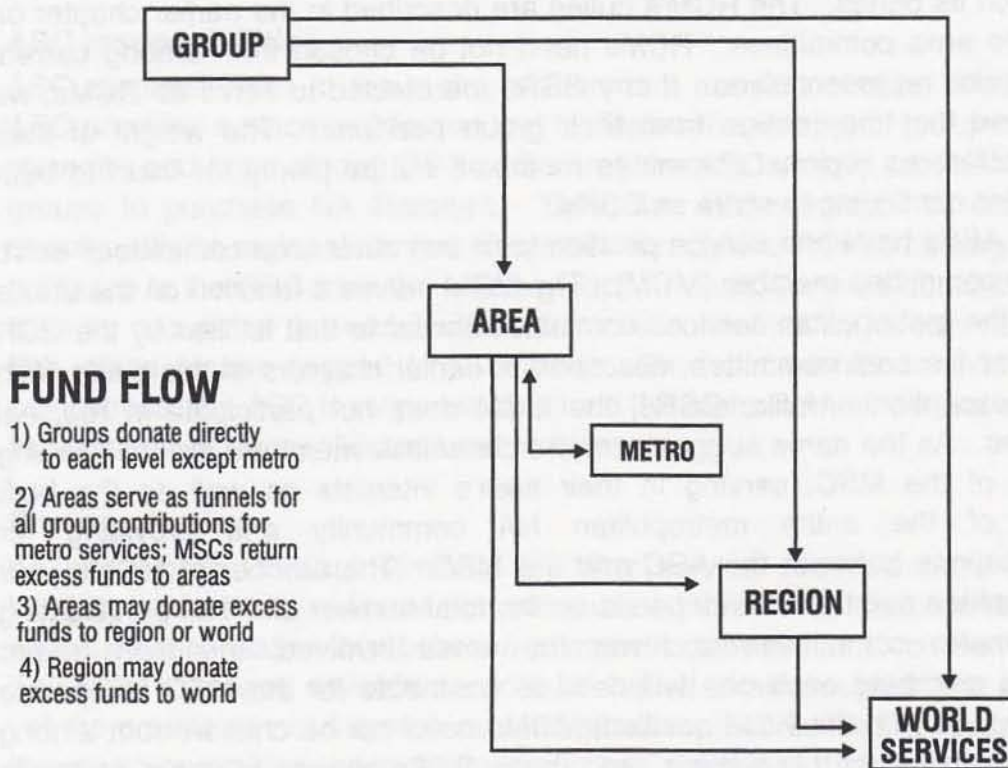

METRO COMMITTEE ORGANIZATION

Metropolitan services committees are organized very much like the full-service area committees described earlier in this guide, with the exception that they receive their funding from their member-areas rather than directly from the community's groups. MSC participants include MCMs elected by member-areas, plus metro committee administrative officers and subcommittee chairs elected by the MSC itself. Metros perform the same services described in the earlier chapter on area committees, with one exception: Metros do not elect regional committee members and do not take part directly in the regional committee itself. However, MSC subcommittee chairpersons do keep in touch with the RSC members given resource assignments in their respective fields of service.

AREA DIVISIONS IN CITIES SERVED BY AN MSC

Finally, a word about ASC divisions in metro communities. As noted in the previous chapter, area committees sometimes grow too large to function effectively, requiring division. This is not a major problem for an MSC member-area since its division does not affect direct services, only the number of GSRs attending a given ASC meeting. The primary concern in dividing a metro ASC is assuring that the split is designed to enhance group support and for no other purpose.

The previous chapter offers much guidance on the area division process. Especially relevant are the paragraphs on choosing new area boundaries. Once a plan is developed, a consensus of all the groups in the existing area must be taken prior to division. Given group consent, the new ASCs can begin meeting immediately.

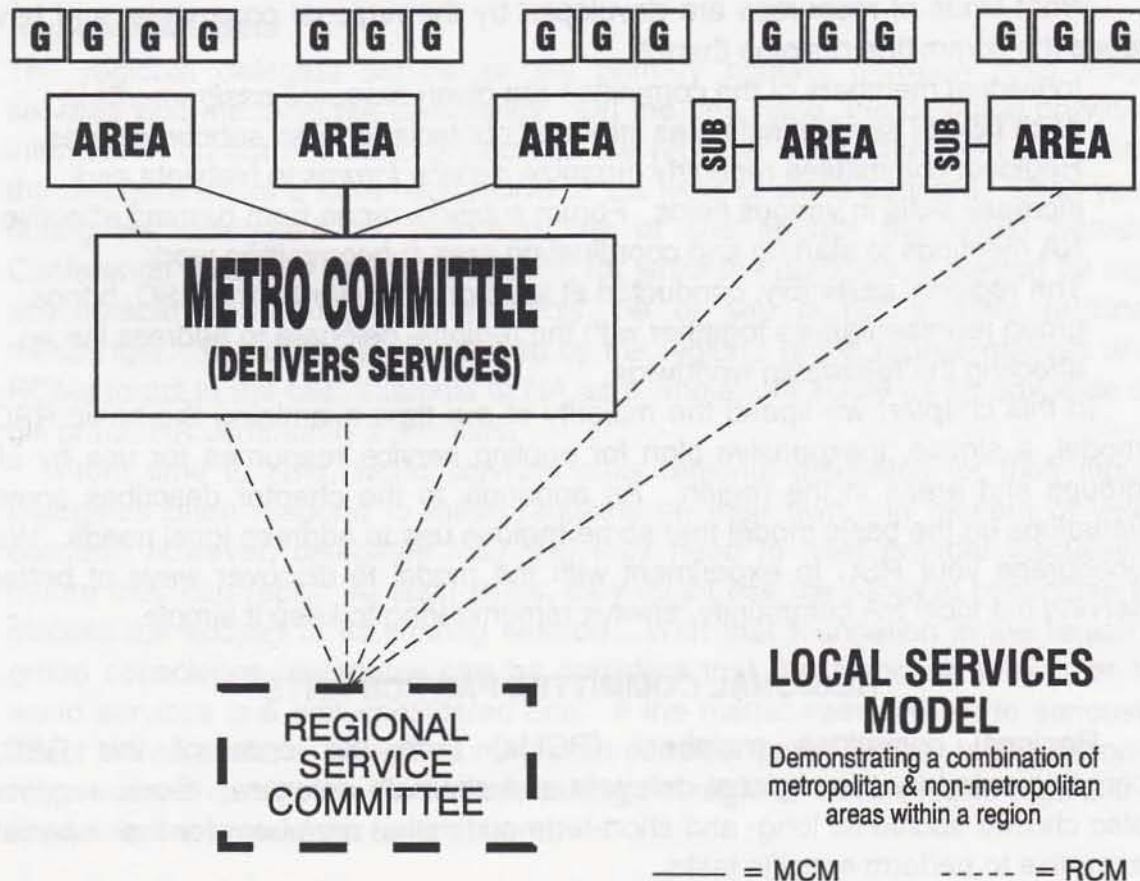

THE REGIONAL SERVICE COMMITTEE

INTRODUCTION

Every element of the NA service structure--whether it be a group, service board, or committee--exists to serve the needs of those who created it. Narcotics Anonymous groups, for instance, host meetings where members can share their recovery with one another and carry the NA message straight to the still-suffering addict. Area service committees provide direct NA services that help groups work better and carry their message farther than they could on their own. In this chapter we'll take a look at *regional service committees* (RSCs). Regional committees generally do not perform direct services--that is, they don't run phonelines, organize H&I panels, or carry out a public information program. Regions are formed simply to pool and develop local service resources that can be used both by groups and areas in better fulfilling their responsibilities.

What kinds of resources are developed by the regional committee, and how does the committee develop them?

- * Individual members of the committee are given *resource assignments* in each field of service, acting as informed contacts for area subcommittees.
- * Regional committees regularly organize *service forums* to highlight and increase skills in various fields. Forum subjects range from running effective NA meetings to starting and coordinating area subcommittee work.
- * The *regional assembly*, conducted at least once a year by the RSC, brings group representatives together with the regional delegate to address issues affecting the fellowship worldwide.

In this chapter, we spend the majority of our time examining the basic RSC model, a simple, inexpensive plan for pooling service resources for use by all groups and areas in the region. An appendix to the chapter describes some variations on the basic model that some regions use to address local needs. We encourage your RSC to experiment with the model to discover ways of better serving the local NA community, always remembering to keep it simple.

REGIONAL COMMITTEE PARTICIPANTS

Regional committee members (RCMs) form the core of the RSC, complemented by the regional delegate and alternate delegate. Some regions also choose additional long- and short-term committee members for their special expertise to perform specific tasks.

Regional committee members (RCMs)

Regional committee members have a big job. At RSC meetings, they share with one another the information and experience of their respective areas. Between

regional committee meetings, they provide their areas with information and contacts from other areas.

Throughout the year, RCMs serve as contact points between world services and the NA groups in their areas. Their reports to the region give the regional delegate a better idea of where world service energies could best be concentrated. RCM reports to the area keep group service representatives informed of world service activities.

Regional committee members may play a variety of roles on the regional service committee. Each year, three RCMs are selected to serve as regional committee chairperson, recording secretary, and treasurer. Others are given *resource assignments*, which will be addressed later in this chapter. Regardless of their additional duties, RCMs continue to serve on the regional committee primarily as RCMs. More on the role of RCMs can be found in the area service committee chapter of this guide.

Regional delegate

The regional delegate serves as the primary contact between NA's world services and the local NA community. On the one hand, the delegate provides information on current world projects to the regional committee. On the other, the delegate offers a local perspective to the work of world services. Each year during the delegate's two-year term, he or she attends the World Service Conference as a fully active participant, for while the delegate is elected by and accountable to the regional assembly, he or she is not a mere regional messenger. The delegate is selected by the region's group representatives and RCMs to act in the best interests of NA as a whole, not solely as an advocate of his or her NA community's priorities.

From time to time, world services asks regional delegates for their input. Delegates often respond to these requests on their own. In matters of wide concern, however, delegates may feel they need to hear broader discussion before they can reply. At such times, they might ask the regional committee to discuss the subject in its sharing session. With that foundation in the region's group conscience, delegates can be confident that the response they offer to world services is a well-considered one. If the matter seems likely to seriously affect NA as a whole, delegates may even consider going directly to the region's NA membership with the discussion, asking the regional committee to organize a service forum around the topic at hand.

Alternate delegate

The regional delegate works closely with the region's alternate delegate. Like the regional delegate, the alternate is a full participant in the regional service

committee. The delegate often consults with the alternate, asking for different perspectives on world service affairs and seeking to involve the alternate in helping carry the workload.

Alternate delegates are welcome to attend the annual meeting of the World Service Conference in the company of their delegates; however, they will be recognized as full participants in the annual meeting of the World Service Conference only in the event of the primary delegate's absence.

Alternate regional delegates attend regional committee meetings and the regional assembly, offering support where they can and learning their way while they're at it. At the end of their terms, alternate regional delegates will very likely be their regions' most promising candidates for full delegate service.

Additional members

Besides RCMs, the regional delegate, and the alternate delegate, many regions seat additional members from time to time. Regions that have conventions or offices usually invite the chairpersons of the boards or committees administering those services to sit on the RSC. Other additional RSC members are called onto the committee because they have special expertise that is lacking among current RCMs. Some additional members are chosen to fulfill long-term resource assignments; others, to help with particular short-term projects. Additional RSC members may be drawn by the regional committee from anywhere at all. However, regions are cautioned against draining the leadership resources of working ASC subcommittees by appointing currently active chairpersons to fulfill RSC resource assignments. Long-term additional members are usually given full rights of participation on the regional committee. Temporary members are generally given rights of participation only in matters specifically affecting their projects.

RESOURCE ASSIGNMENTS

Some RCMs are elected to serve as regional committee officers; others are given *resource assignments*. These RCMs take on the responsibility of becoming the best-informed people they can be regarding particular fields of service, including:

- * translation work,
- * public relations,
- * hospitals and institutions service,
- * phonline coordination, and
- * outreach.

Regional resource persons make it their job to know the manuals and bulletins on their resource subjects backwards and forwards. Though by no

REGIONAL SERVICE MODEL

without regional subcommittees

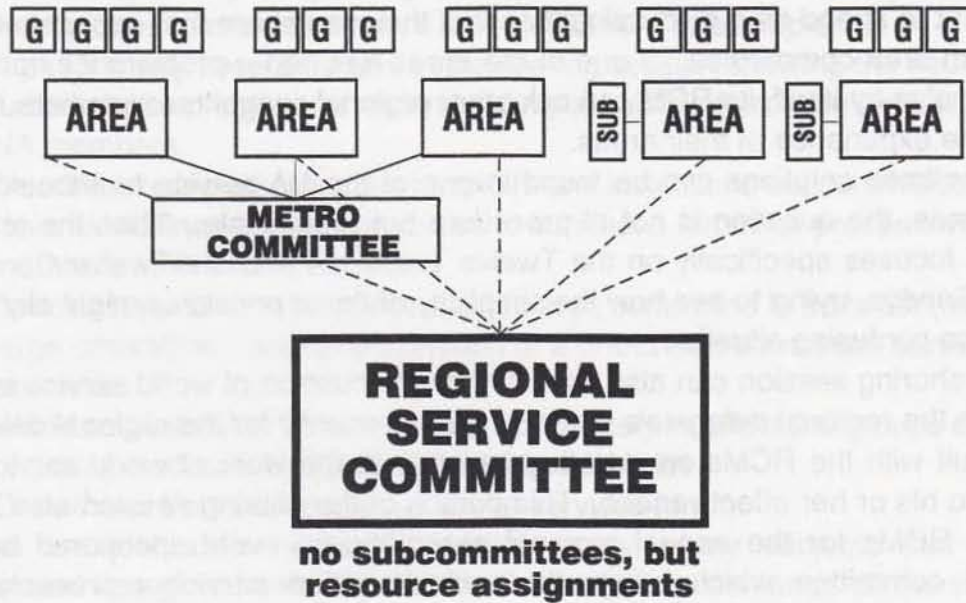

means "authorities" or "directors," they take the time to keep in regular touch with the chairpersons of area or metro subcommittees in their resource fields and, if asked, help untangle local service problems. Resource persons can do this individually or by hosting frequent, informal sharing sessions for local subcommittee chairpersons. If an area committee does not have an H&I, PI, or phonline subcommittee, it can contact the resource person in that field of service for help in forming one. Finally, regional resource persons serve as intermediaries in their fields of service between area or metro subcommittees and state, provincial, or national government agencies.

REGIONAL COMMITTEE MEETINGS

At RSC meetings, the committee tries to get a sense of the needs of its own groups and areas as well as those of the fellowship worldwide. Following area committee and resource assignment reports from the RCMs, the regional delegate briefs the committee on world service developments. Much of the remainder of the meeting is spent in a sharing session that lays the groundwork for discussions of service forum and regional assembly plans at the end of the meeting.

The regional committee's sharing session begins with discussion of the challenges and innovations disclosed in the RCM reports. If a subcommittee of one of the areas has taken a new tack in approaching a particular job, the RCMs may want to spend time discussing it so that they can share that experience with their own area committees. If one of the areas has had a problem it's not been able to solve by itself, its RCM can ask other regional committee members to talk about the experience of their areas.

Sometimes solutions can be found in one of the NA service handbooks. At other times, the question is not of procedure but of principle. Then the sharing session focuses specifically on the Twelve Traditions and the Twelve Concepts for NA Service, trying to see how the simplicity of those principles might clarify an otherwise confusing situation.

The sharing session can also be a time for discussion of world service issues raised in the regional delegate's report. This opportunity for the regional delegate to consult with the RCMs on questions relating to the work of world services is crucial to his or her effectiveness. This portion of the sharing session also helps prepare RCMs for the annual regional assembly, an event sponsored by the regional committee which brings the region's group service representatives together to review topics of importance in world service. Maintaining fluency in world service issues is doubly important for RCMs, since new regional delegates and alternate delegates are drawn from among them.

Because of their relative informality, it's especially important that regional committees maintain good relations among their members. Should the need arise, the sharing session provides committee members an opportunity to exercise NA's Tenth Concept by petitioning "for the redress of a personal grievance, without fear of reprisal." The committee will take great care to hear such grievances well, responding swiftly and fairly, if it hopes to continue operating smoothly.

Once the committee's sharing session is over, it's on to business of planning service forums and the regional assembly. The business portion of an RSC meeting is usually conducted by consensus rather than voting. The process emphasizes development of the RSC's group conscience, allowing decisions to arise naturally from a thorough consideration of the matters at hand. This suits both the nature of the RSC as the region's service resource pool and the kind of business being conducted: preparing to help the region-at-large inform itself and develop a collective conscience.

SERVICE FORUMS

In the sharing session, the regional committee focuses much of its attention on group and area needs. With that perspective, the committee is in a good

position to consider its agenda of service forums--what kinds of forums are needed and where. Regional service forums not only react to existing needs or problems, they anticipate challenges likely to face the NA community in the future and help groups and areas prepare to meet them. For example:

- * A pattern may have emerged in the sharing session showing the need to further develop a general understanding of public information work among NA members.
- * An area forming a brand new hospitals and institutions subcommittee might have asked the regional committee to conduct a forum for prospective members of the subcommittee.
- * Special support may be needed for an area committee in transition, either a large committee considering division or a brand new committee serving a new area.
- * World services may be considering action likely to affect the groups directly, requiring discussion from the fellowship worldwide.
- * Or perhaps it's time for another group services forum.

These are just a few examples of the many, many subjects that can be addressed in regional service forums. Forum topics can range all the way from taxes and liability insurance for service committees to sponsorship and Twelfth Step work--anything useful to the areas and groups served by the region. Whatever the needs, the regional committee takes a look at its calendar, considers its resources, and develops plans for upcoming forums.

Regional service forums are usually organized by the entire regional committee, although sometimes a small ad hoc committee of RCMs and others will be formed to conduct one specific forum. When planning a forum, the regional committee should consult with the area service committee responsible for the territory in which the event is to be held. This is especially important in regions where area committees assume the responsibility of making arrangements for forum facilities, leaving the regional committee free to focus its attention on developing an agenda for the forum. If the forum is being organized primarily to serve one particular area, the regional committee should involve some members of that area committee in developing plans for the forum.

The regional committee can draw upon a number of resources when developing service forums. Committee members may know of a similar forum that has been conducted in a neighboring region. A phone call to a member of that regional committee, and perhaps an invitation to attend, can make additional experience available to the forum. Further support for regional forums may be available from our World Service Office. A wide range of bulletins and handbooks covering specific topics and fields of service is available. The WSO may also be able to provide descriptions of forums other regions have conducted

on similar subjects. For information and materials, contact the World Service Office.

REGIONAL ASSEMBLY

At least once a year, usually two or three months prior to the annual meeting of the World Service Conference, the regional committee organizes an assembly of group service representatives. Regional assemblies bring representatives of NA groups together with RCMs and the regional delegate for the purpose of developing a collective conscience concerning issues affecting Narcotics Anonymous worldwide. That direct contact between the groups and the conference helps keep our world services attuned to the needs of our fellowship. Without the kind of primary foundation provided by the regional assemblies, it would be much more difficult for the World Service Conference to effectively address the concerns of the NA groups. Regional assemblies are a key ingredient in the maintenance of the NA groups' final responsibility and authority for our fellowship's services, spoken of in our Second Concept.

Most regional assemblies start with all participants--GSRs, RCMs, and the regional delegate--gathered together for an opening address. Then the assembly usually divides into smaller groups of between seven and fifteen people each so that everyone can take a meaningful part in discussions. These discussion groups, led by RCMs, consider a variety of issues related to world service. Some of these are issues covered in pre-conference mailings from world services, including the approval of new NA literature and other proposals that would affect NA as a whole; some are subjects the RSC has raised for discussion; others come from individual GSRs in each group. When panel discussions conclude, all the GSRs and RCMs gather in a large group to hear reports from spokespersons selected by each panel. A sharing session, in which all participants are encouraged to speak their mind, follows the reports. These discussions give the delegate clear indications of the region's collective conscience concerning world issues, indications that will guide the delegate when participating in the world conference. If the assembly wishes, it can formalize its conscience regarding world service affairs by passing resolutions on issues of particular concern.

Regional delegate elections

An additional expression of our Second Concept at the regional assembly occurs when group service representatives take part in electing the regional delegate and alternate. Since the delegate and the alternate serve concurrent two-year terms, elections usually take place every other year except when a delegate or alternate resigns in mid-term. Some regions have delegates begin their terms

immediately upon election; others begin new delegate terms shortly after the annual WSC meeting.

Because alternate delegates have spent two years becoming familiar with the World Service Conference, they are usually affirmed to replace outgoing delegates; then the assembly only has to elect a new alternate delegate. If the alternate is not affirmed as regional delegate, however, the assembly elects a new delegate and a new alternate at the same time. Under such circumstances, special care should be taken to select a regional delegate who is already fairly familiar with current world service affairs.

The delegate and alternate are usually chosen from current RCMs. Group service representatives and RCMs are all eligible to take part in the selection process. If both regional delegate and alternate delegate are to be selected at the same assembly, separate balloting rounds are used to select each of them.

What the Fourth Concept says about our leaders in general applies especially to the regional delegate: "Effective leadership is highly valued in Narcotics Anonymous. Leadership qualities should be carefully considered when selecting trusted servants." The World Service Conference operates with the understanding that regional delegates are among the most experienced and knowledgeable people each region has to offer. Delegates need to have a thorough understanding of the Twelve Concepts, the Twelve Traditions, and the service structure as well as detailed knowledge of activities and issues in the groups and areas which make up their region. They are called upon for vigorous service from all directions; they must be fit to answer the call.

Just as area committees generally do not select the same individual to serve more than two consecutive terms as RCM, so do most regional assemblies observe the practice of trusted servant rotation when selecting regional delegates, and for many of the same reasons. By periodically replacing delegates, the region is assured of being provided with varying views of world service affairs. A conference that constantly sees new faces, hears new voices, and is encountered with new outlooks on world service work will be better able to meet the challenges of each new year.

Once their terms are done, past regional delegates may be asked to serve either the region or world services in various capacities. Their experience lends stability to the services of both bodies. Each region is responsible to establish its own delegate clean-time requirements. However, assemblies should keep in mind that most world service positions have clean-time requirements as well. When the delegate candidate being considered completes his or her term, will he or she have enough time clean to be eligible for those positions?

REGIONAL FINANCES

Money is handled at the regional level in pretty much the same way it's managed by area treasurers. The regional committee as a whole considers its projected expenses and authorizes expenditures to cover them. These costs often include:

- WSC participation expenses for the regional delegate and alternate,
- space rental for committee meetings,
- service forums,
- the regional assembly,
- activities, and
- mailings.

Some regional committees offer assistance in covering their members' travel expenses related to attending RSC meetings. Most regions contribute to world services whatever money they have left after paying their own expenses.

Two-signature checks and a consolidation of responsibility for all regional funds help the regional treasurer manage contributions and the reimbursement of expenses in a responsible way. Additional suggestions for handling the regional treasury can be found in the *Treasurer's Handbook*, available from the World Service Office.

FUND FLOW

- 1) Groups donate directly to each level except metro
- 2) Areas serve as funnels for all group contributions for metro services; MSCs return excess funds to areas
- 3) Areas may donate excess funds to region or world
- 4) Region may donate excess funds to world

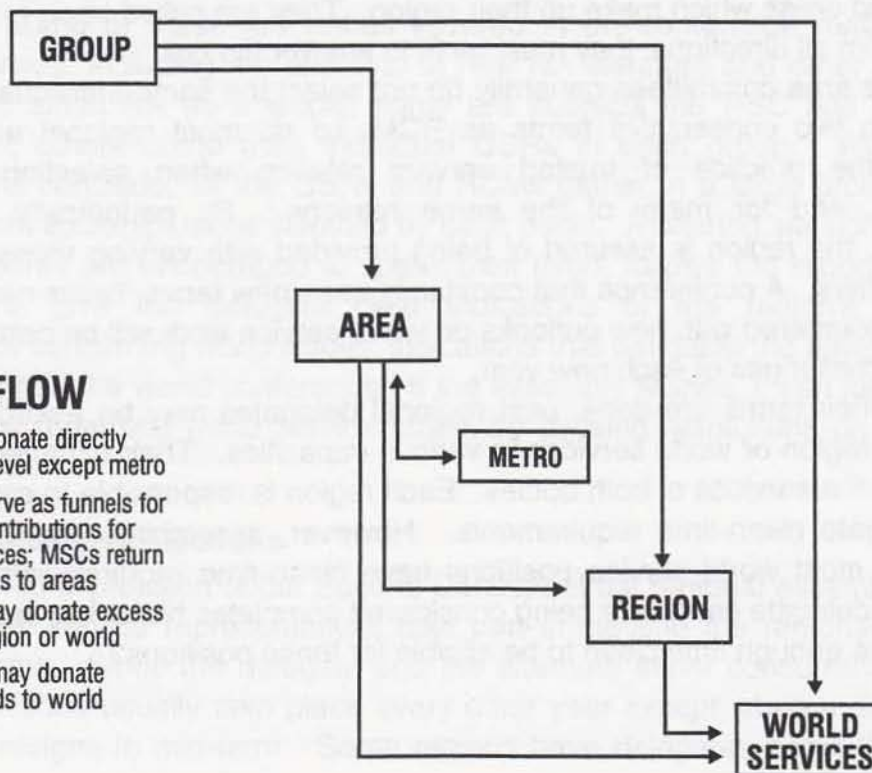

REGIONAL ACTIVITIES

Besides forums and assemblies, some regions host a variety of additional fellowship activities including conventions, campouts, speaker meetings, and dances. Some regions hold such events in conjunction with their RSC meetings. Regionwide activities can foster a broader sense of unity among members of all the groups and areas served by the regional committee. For more information, contact the World Service Office.

Organizing regional activities can be very taxing, especially for smaller regional committees. The task of organizing a regional convention, in particular, is a major undertaking. Most regions conducting annual conventions create a standing subcommittee to handle the job. Such a subcommittee is, of course, always accountable to the region establishing it and gives a thorough report of its activity at each regional committee meeting.

Conventions and other regional activities should serve primarily as celebrations of recovery, not sources of RSC operating funds. Why? One reason is that, as the essay on our Eleventh Concept suggests, "we find it easier to maintain a strong link between our groups and our other service units... when we make a commitment to fund the work of each level of the service structure exclusively through group contributions." The region that begins depending heavily on income from regional activities for its operating funds may find itself less focused on the needs of its NA community than a region depending primarily on group contributions.

We have also found activities to be notoriously--sometimes disastrously--unreliable sources of funds. An event that often produces substantial net income may take a huge unexpected loss one year. If this happens, the regional committee that depends on income from that event for its operating funds will have to cease operations for awhile, leaving the entire regional NA community without resource development services.

For these reasons we recommend that, once the region establishes an initial "seed fund" for its convention subcommittee, regional committee money and convention subcommittee money be held and accounted for separately. Regional conventions are then made self-supporting from their own income, charging only enough in registration fees to cover the costs of putting on the convention. Because the efforts that result in the generation of convention profits are contributed by NA members in the spirit of our Seventh Tradition, it is not inappropriate to deposit minimal excess proceeds in the RSC operating fund.

Given the large amounts of money and the serious obligations involved in operating a regional convention, an RSC can find itself in deeper trouble than it can imagine in a very short period of time if it's not careful. For this reason, we especially encourage you to refer often to the *Convention Handbook*, which

contains more detailed information on regional conventions. The *Convention Handbook* is available from the World Service Office.

NA's World Convention Corporation sometimes conducts workshops that bring local convention volunteers together with members of the world convention team to review the latest information on NA convention planning. Additional consultation for new convention subcommittees or those experiencing difficulties is also available from the World Convention Corporation. For further information, contact the World Service Office.

**VARIATIONS ON THE
BASIC REGIONAL MODEL**

REGIONAL SUBCOMMITTEES

The regional service committee is a resource pool, gathering service information and experience to guide and strengthen the areas it serves. To do this, each regional committee organizes itself and performs its duties differently, according to the needs of its member-areas.

In some places, the RSC is primarily a sharing session. RCMs come

REGIONAL SERVICE MODEL
with regional subcommittees

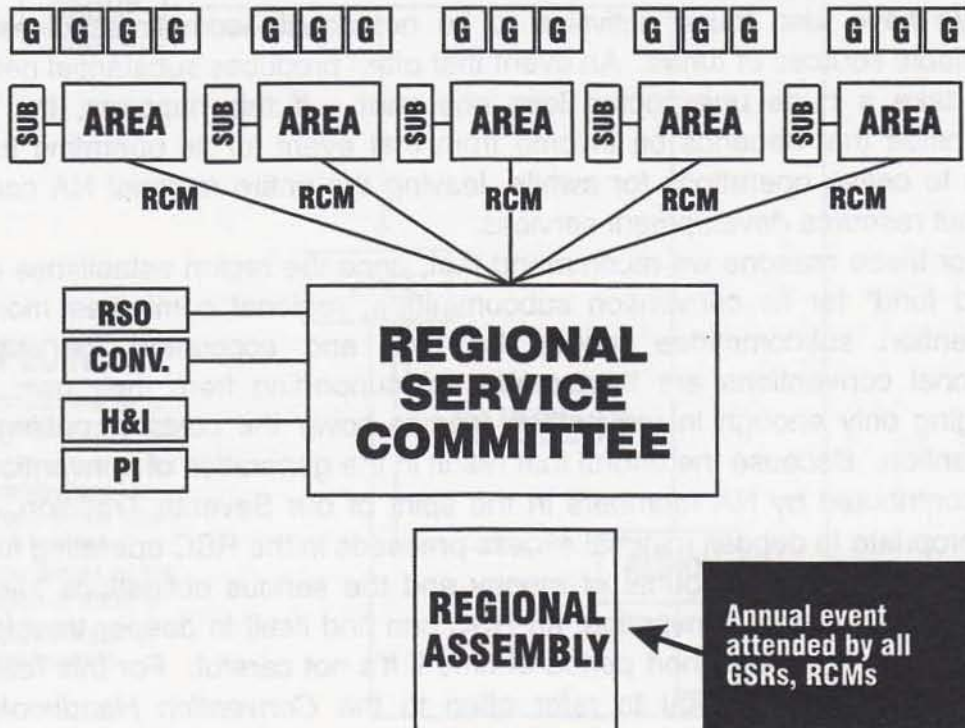

together, discuss with one another the service experience of their ASCs, and return to their areas with information on how services are performed elsewhere.

In other places, regional-level subcommittees composed of chairpersons of corresponding area-level subcommittees gather to share experience and information in their particular fields of service.

In still other regions, some RSC subcommittees provide direct services affecting all the region's areas or provide outreach to portions of the region not served by any area committee. As has been noted in other chapters, it's the function, not the form, that's important, and the primary function of the RSC is to pool the service resources of its areas.

Subcommittees deliver their reports to the full committee following reports from the RCMs and the regional delegate. If a subcommittee needs to place a motion before the regional committee, that motion can be considered following the sharing session.

Sharing-format subcommittees

Some regions formalize the sharing sessions often conducted by resource persons, creating sharing-format subcommittees. These subcommittees, led by RCMs, are composed of the chairpersons of the area subcommittees for each field of service. For example, a sharing-format regional H&I subcommittee is led by the RCM or RCMs who've been given the H&I resource assignment and is composed of all the area H&I subcommittee chairpersons in the region. Sharing-format subcommittees meet on a regular basis, sometimes immediately before or after the full regional committee meeting and sometimes at a different time and location. Regional sharing-format subcommittees are not created to take over the service responsibilities of the region's member-areas. Rather, they help strengthen weak area subcommittees and, upon request, assist ASCs that are without subcommittees in particular fields of service to form their own.

Direct service subcommittees

Regional committees organize themselves according to the needs and resources of their member-areas. It is generally recommended that, whenever possible, direct services be administered by area or metro service committees. (See the earlier chapters for more information on ASCs and MSCs.) Area and metro committees are closest to where most direct services will actually be delivered and thus are more likely to be able to administer those services efficiently and responsively.

However, in some locales, some direct NA services can be administered only by the regional committee. Regional direct services may be administered by the regional committee itself, by RCMs given resource assignments, by regional ad

hoc committees established to conduct specific projects, or by standing regional subcommittees. Each regional committee will organize itself to conduct whatever direct service operations it may be required to administer as it sees fit, subject to the needs and direction of its member-areas.

In young NA communities and mostly rural territories, the region's member-areas may not be able to provide service to the entire state, province, or country. In these places, regional committees frequently provide a variety of *outreach services*. Correspondence is maintained with geographically isolated NA groups, keeping them in touch with the larger world of Narcotics Anonymous and providing them with the assistance usually offered by area service committees. When other NA groups are formed in close proximity, the region assists them in forming an area committee so that those groups can support themselves and provide their own direct services. In the meantime, contacts with local treatment agencies and practitioners, civil authorities, and community organizations may be established by the regional committee, generating greater awareness of the NA program. Responses may also be provided to public information queries.

In some regions, member-areas share *common needs* for certain direct services such as media relations or phonenumber administration. If only a few of the

AREA SHARED SERVICES COMMITTEE

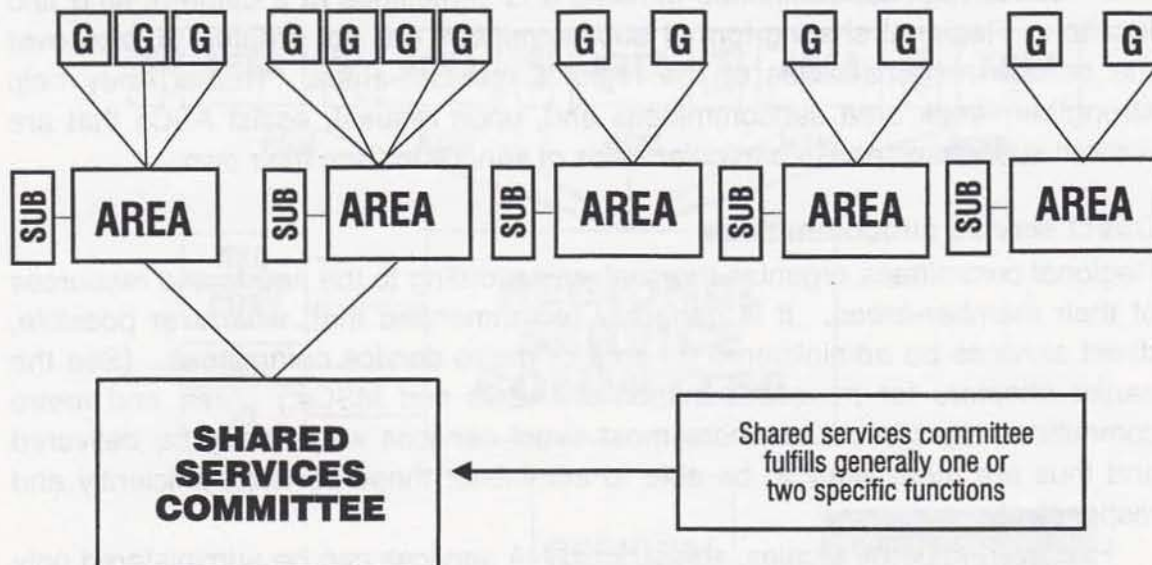

region's areas share a particular common need, those areas should cooperatively establish a special committee of their own to meet that need, funded by and accountable to all the areas joining to form the shared services committee. (See the section titled "Or Not to Metro" in the earlier chapter on area divisions for more information on shared services committees.) However, if all the region's areas share a particular need, it is appropriate for them to ask the regional committee to administer services which meet that need.

ADDITIONAL REGIONAL ASSEMBLIES

Some regions conduct more than one WSC-oriented assembly per year. One, held a few months before the annual conference, advises the regional delegate of the conscience of the region's group representatives regarding world services. A second assembly gives the regional delegate an opportunity to report to the GSRs what happened at the WSC meeting. Other regions conduct additional assemblies that focus not on world services but regionwide fellowship concerns.

In a geographically far-flung state, province, or country, the regional committee may find it advantageous to define two or more assembly districts for the convenience of GSRs in widely separated parts of the state. Similarly, in a heavily populated territory, assembly districts may be defined so as to accommodate the large numbers of GSRs. In each district, the regional delegate meets in an assembly with the district's RCMs and GSRs to develop a conscience concerning world service affairs. In regions with more than one assembly district, the regional delegate can be elected by the region's RCMs at a special RSC meeting held after all the district assemblies have been conducted.

INTERREGIONAL COOPERATION

Our fellowship's Eighth Concept suggests that "our service structure depends on the integrity and effectiveness of our communications." Groups work more effectively when they communicate and cooperate with one another; the same applies to regional committees. Of course, each region benefits from the communication facilitated by the World Service Conference and the world service forums that are held during the year. For more information on world service forums, contact the World Service Office.

But just as multiregion states form shared service committees to handle NA service interactions with state agencies, so do regions in adjacent provinces or countries sometimes organize joint efforts to address needs unique to their parts of the world. Such collective efforts sometimes focus on a specific concern, such as PI work in a media market that straddles two or more neighboring regions. Other joint efforts might be more general in application, organizing multiregional

learning days or service-oriented sharing sessions. Such forums can provide the means by which NA communities communicate, cooperate, and grow with one another.

However, our fellowship's service experience cautions us against organizing cooperative forums unless the need for such forums is clear. Activities like the world service forums may already provide adequate opportunities for interregional communication. If this is the case, it may well be a duplication of effort and expense to organize additional forums.

Our experience has also shown that interregional conferences or assemblies may tend to become political in focus, transforming themselves unintentionally from sharing sessions into decision-making bodies. We encourage regions to cooperate and communicate with one another in meeting their common needs, but we caution them against duplicating efforts, wasting NA resources, and politicizing their cooperative ventures.

REGIONAL SHARED SERVICES COMMITTEE

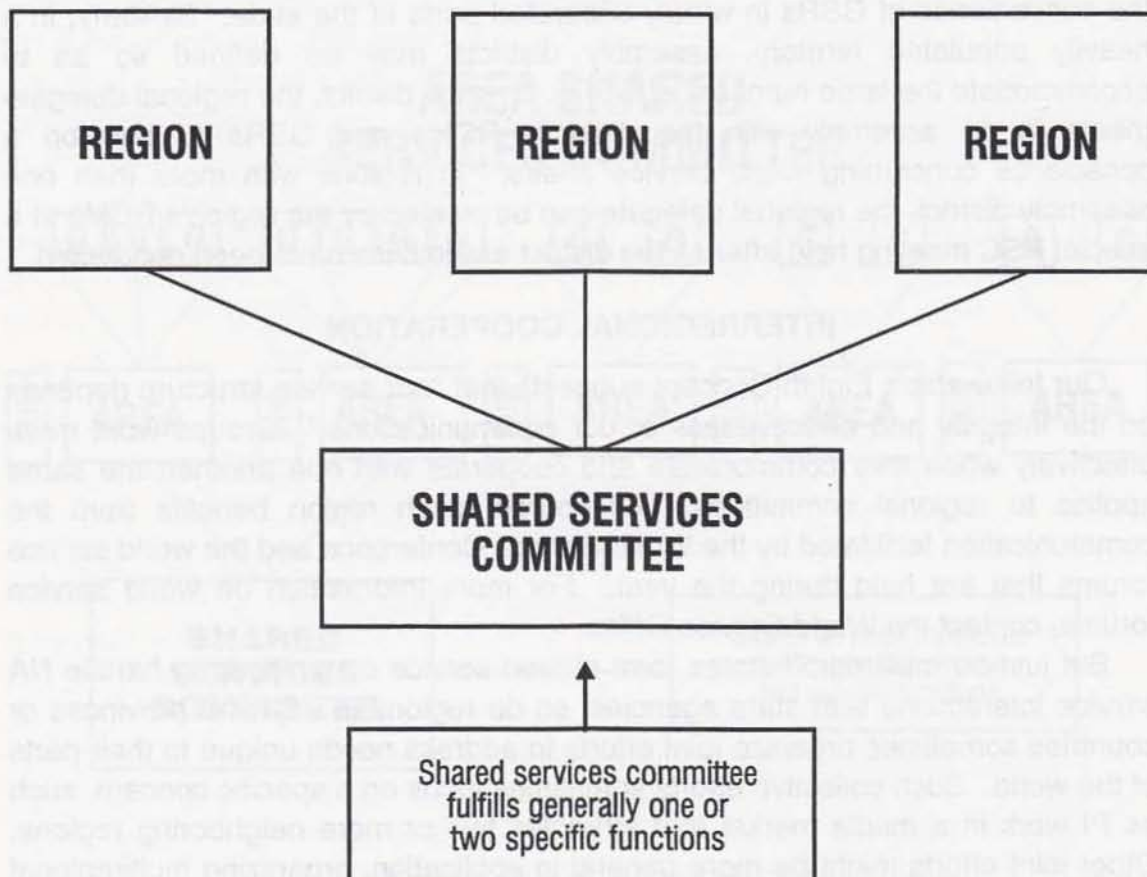

LOCAL SERVICE CENTERS

Local service centers--also called central offices, area service offices, or regional service offices--are established for a variety of reasons. Some serve merely as storage locations for the area committee's stockpile of NA books and pamphlets. Others fill local literature orders by mail and sell materials over the counter during business hours. Some area and regional service offices facilitate the operation of local NA phonelines. A few local service centers are large enough that they can make space available for service committee meetings and storage of committee records. Some even have special workers available to assist service committees with their projects. Regardless of what else they do, local service centers provide the NA community with a physical presence and a public identity, a specific point at which Narcotics Anonymous and the larger community can interact with one another.

Local service centers become incorporated in order to meet requirements of local and national law regarding business licenses, taxes, insurance, and employment. The body that manages the local NA office corporation is called a board of directors, but it functions in almost exactly the same way as a subcommittee in relation to the committee that creates it. Though the office board is given a certain degree of independence in managing its affairs, the board is obligated to provide complete reports of its activities and finances on a regular basis and is subject to the direction of the committee that created it, whether that committee be an area, metro, or regional service committee.

An NA community considering the possibility of opening a local service center will encounter a number of challenges. Local service centers require substantial business expertise in order to operate effectively. Legal problems often arise, most often associated with incorporation procedures, taxes, and personal liability. Offices are expensive and usually do not generate enough net income from literature sales to support themselves. Are the groups in the territory to be served by the office aware of this, and are they willing to pay for the office's operating expenses? Offices also require a great deal of attention from the NA community's most knowledgeable and experienced trusted servants, who are usually called upon to serve on the office board.

Despite the numerous challenges to be overcome, some NA communities have managed to effectively integrate the local office into their overall service delivery program without serious disruption. Those who have done so have moved cautiously and carefully through the maze of questions about local community strength, personnel and financial resources, business organization, inter-service relations, and legal restrictions that must be answered before an office can be opened. They have also given consistent attention to the

maintenance of office affairs once the service center has opened its doors for business.

Because the needs of each community and each local service center vary so greatly, it's not been possible to create a uniform handbook providing clear direction on how to operate all local service centers. The World Service Office, however, has substantial experience in advising local offices in many phases of their work and will be happy to lend assistance to area or regional committees who may be considering the creation of a local service center. The World Service Office regularly conducts workshops on local service center operations, bringing board members and special workers from a number of area and regional offices together with business committee members and WSO staff for the purpose of sharing information and brainstorming problem topics. For information, contact the World Service Office.

SAMPLE RULES OF ORDER

On the following pages, you'll find a simple set of rules of order. They have been adapted from *Robert's Rules of Order, Newly Revised*, which in turn are based on the Rules of the US House of Representatives. These sample rules differ in some details from *Robert's Rules*; to cover such differences, your committee may wish to make a blanket decision to accept these rules as authoritative. In countries where *Robert's Rules of Order* are not in common use and where some other body of parliamentary rules is more commonly used by deliberative assemblies, service committees may want to consider adapting these rules so that they conform to those commonly in use in their own lands.

DECORUM STATEMENT

Meetings will be conducted according to these rules of order, adapted from *Robert's Rules of Order*. This time-honored system for conducting business is the clearest way yet devised for getting a maximum amount of business done in a minimum of time, regardless of the degree of disagreement among the participants.

These rules are meant to be used as tools to help us make orderly collective decisions in a cooperative, respectful way in the spirit of our Twelve Concepts; please do not use them as weapons against one another. We encourage all participants to become familiar with these rules of order and conduct themselves accordingly.

Once the meeting is under way, only one matter will be before the committee at any one time and no other discussion is in order. Please respect the chairperson's right to be in control of the process of this meeting so that you can have maximum benefit of its content.

DEBATE, LIMITS

Debate is the formal exchange of views on an idea. Unless otherwise specified, debate on both main motions and parliamentary motions is usually limited to two or three pros and two or three cons (speakers for and against the motion). Speakers addressing a motion in debate usually have two or three minutes in which to speak their minds.

MOTIONS

There are two basic types of motions. It is important to understand the difference between them. The two kinds of motions are *main motions* and *parliamentary motions*.

MAIN MOTIONS

A *motion* is a statement of an idea a committee member wants the committee to put into practice. After being recognized by the chairperson, the member says, "I move that such-and-such be done by (this committee, one of its subcommittees, or a particular individual) under these terms." The person making the motion then speaks briefly about why he or she feels the idea is important; this is called speaking to the intent of a motion. Because the exact wording of all motions must be recorded in the minutes, the maker of the motion should write it out whenever possible. This is especially important for long or complicated motions.

Every motion requires a *second*--the backing of another person who either wants the idea put into practice or simply wants to see further discussion of the idea take place. After one person makes a motion, the chairperson will ask whether the motion has a second. The seconder simply raises a hand and, when recognized by the chair, says, "I second that." If nobody seconds a motion, the chair will say, "The motion dies for lack of a second." This means that the idea will not be discussed any further because there is not enough interest in it. The committee then moves on to other business.

Once a motion has been made, the chairperson may rule it *out of order*. A motion may be ruled out of order for any one of a number of reasons: the motion goes against the committee's standing policy, clearly contradicts one of the Twelve Traditions or Twelve Concepts for NA Service, or is inappropriate at the particular point in the meeting at which it is made. *Robert's Rules of Order* can be consulted for more specific examples of motions which are out of order at any given time.

Any member of the committee who wishes to challenge a ruling made by the chairperson may *appeal* that ruling, as described below. If no appeal is made, or if the decision of the chair is upheld, the committee moves on to other business.

PARLIAMENTARY MOTIONS

Parliamentary motions can be best understood as "sub-motions" made during debate on a main motion that affect that motion in some way. There are many more of these than space and practicality permit us to include here, but a few that seem to be the most practical are discussed below.

1. Motion to AMEND.

SIMPLE majority required.

Is DEBATABLE.

This is perhaps the most commonly used parliamentary motion. During debate on a motion, if a member feels that the motion would benefit from a change in its

language, that member can say, "*I move to amend the motion...*" and suggest specific language changes in the motion. Ordinarily, an amendment must be moved and seconded before it can be debated. When debate on the amendment is exhausted, the body votes on the amendment. Then, debate resumes on the merits of the main motion (as amended, if the amendment has carried). When debate is exhausted on the merits of the main motion itself, a vote is taken and the body moves on to the next item of business.

If an amendment is offered and the persons making and seconding the original motion accept it, no second is required, no debate is called for, and no vote need be taken on the amendment; debate proceeds as if the main motion had been formally amended. This is called making a *friendly amendment*.

2. Motion to call the PREVIOUS QUESTION.

TWO-THIRDS majority required.

Is NOT DEBATABLE.

For our purposes, this may be the most important parliamentary motion. Use it often. This motion is made by a member saying, "*I call for the question,*" or "*I move the previous question.*" It is another way of saying, "I move that debate stop right now and that we vote immediately." This is one of many motions that can be used to prevent needless, lengthy debate once an issue is clearly understood. This motion is in order after any speaker is finished. You need not be called on. The chair must recognize you when you make this motion, and a vote must be taken with no debate. If two-thirds of the body feels that no more debate is necessary, then it is time to vote and move on.

One point worth making about this motion is that you must be careful not to squelch debate before an issue has been thoroughly aired. Be sure to vote "no" to this motion if you are still confused about the issue at hand or are unsure of how to vote. By allowing debate to continue, we avoid half-baked decisions about half-understood questions. On the other hand, the liberal use of this motion makes it unnecessary for the chair to be heavy-handed in stopping discussion, because the chair knows you will stop it soon enough.

3. Motion to TABLE.

SIMPLE majority required.

Is NOT DEBATABLE.

One way of disposing of a motion that is not ready for a vote is to *table* it. This is done by saying, "*I move we table this motion until such-and-such a date/meeting.*" This motion is not debatable; if it is made and seconded, it is voted on immediately. If it fails, debate continues on the motion itself. If it passes, the committee moves on to its next item of business. The tabled motion will be included in the committee agenda on the date specified.

4. Motion to REMOVE FROM THE TABLE.**SIMPLE majority required.****Is NOT DEBATABLE.**

A motion that has been tabled can be taken up before the time originally set in the motion to table. This is done by saying, "I move to remove from the table the motion to such-and-such." If this motion passes, the motion that had been tabled becomes the main motion and debate on it begins again. If the motion to remove from the table fails, the body moves on to the next item of business.

5. Motion to REFER.**SIMPLE majority required.****Is DEBATABLE.**

Sometimes the committee does not have enough information to make an immediate decision on a main motion. Such motions can be removed from debate and sent to either a standing subcommittee or an ad hoc committee for further study. This can be done by a member saying, "*I move to refer the motion to the such-and-such subcommittee.*" If the motion to refer is seconded, the body may debate it before voting. If the motion to refer passes, the committee moves on to its next item of business. If the motion to refer does not pass, the committee either continues debating the main motion or votes on it.

The subcommittee to which a motion is referred will take it up at its next meeting. The subcommittee will report back on what it has come up with at the next meeting of the full committee.

6. Motions to RECONSIDER or RESCIND.**MAJORITY required varies.****Is DEBATABLE.**

Sometimes a member feels that a motion the committee has passed will prove harmful. That member can move to either *reconsider* (reopen for debate and voting) or *rescind* (void the effect of) the original motion.

There are a few conditions on motions to reconsider or rescind:

- * The motion must have been passed in either the last month's or the current meeting.
- * The member making the motion must have information on the issue that was not available in the original debate on the motion.
- * The member must have been with the winning side in the original vote.

These limits are placed to protect the committee from having to reconsider again and again the motions it passes while still allowing it to examine potentially harmful situations it has created inadvertently. If any of these requirements are not met, the chairperson will declare the motion out of order.

The motion to reconsider requires a simple majority.

The motion to rescind requires a simple majority, provided that committee members were informed prior to the meeting that such a motion would be made. If prior notice is not given, the motion to rescind requires a two-thirds majority.

7. Request to WITHDRAW A MOTION.
UNANIMOUS CONSENT required.
Is NOT DEBATABLE.

Once a motion is made and the debate begins, the maker of the motion may ask to withdraw it. The chair asks if there are any objections. If there is even one objection, the motion stays on the floor and debate resumes. If there are no objections, the motion is withdrawn and the body moves on.

8. Offering a SUBSTITUTE MOTION.
SIMPLE majority required.
Is DEBATABLE.

A *substitute motion* is the same thing as an amendment to a main motion. The only difference is that it is offered to entirely replace the original idea, instead of merely revising a portion of it. It is handled in the same way an amendment is handled.

9. Motion to ADJOURN.
SIMPLE majority required.
Is NOT DEBATABLE.

Any voting member may move to adjourn at any time. This motion is always in order, is not debatable, and requires a simple majority to pass. Obviously frivolous motions to adjourn may be ruled out of order. After all business is finished, the chair may declare the meeting adjourned without a motion.

OTHER PROCEDURES

In addition to parliamentary motions, there are other ways in which members may alter or clarify the proceedings. Here are a few of the most common.

Order of the day

If a committee member feels that business is going too far astray from the original agenda, that member can help get things back on track. The member says, "*I call for the order of the day.*" This means, "I move that the chair bring us back on track and conduct the meeting according to procedure, adhering to the agenda." This does not require a second, is not debatable, and does not even *require* a vote--the chairperson is obligated to enforce the request unless two-thirds of the body tell the chair otherwise.

Point of information

If a committee member needs certain information before making a decision about a motion at hand, that member can say at any time to the chairperson, "*Point of information.*" This means, "I have a question to ask," *not* "I have information to offer." One does not need a second to raise a point of information; it is neither debatable nor to be voted upon. The person raising the point of information may ask the question of either the chairperson or another member of the body.

Point of order

If it appears to a committee member that something is happening in violation of the rules of order, and if the chairperson has not yet done anything about it, the member can ask the chairperson for clarification of the rules at any time. The member may simply say out loud, "*Point of order.*" The chairperson then says, "What is your point of order?" The member then states the question and asks the chairperson for clarification. If the chair agrees that the rules are not being followed, the chair says "Your point is well taken" and restates the appropriate rule. If the chair does not agree, the chair says, "Overruled." This decision, as all others, can be appealed.

Point of appeal

Any time the chair makes a decision, that decision may be appealed. Any voting member who wishes to appeal a decision may do so by saying, "*I appeal the decision of the chair.*" If the appeal is seconded, the chair then asks, "On what grounds do you appeal my decision?" The member states the reasons. The chairperson then speaks briefly to the intent of the ruling being appealed. The body may then debate the ruling and the merits of the appeal. A vote is taken, requiring a simple majority to overrule the original decision of the chair.

Parliamentary inquiry

If a committee member wants to do something but doesn't know how it fits in with the rules of order, all that member has to do is ask. At any time, a member may simply say out loud, "*Point of parliamentary inquiry.*" The chairperson must immediately recognize the member so that person may ask how to do such-and-such. The chair will answer the question, possibly by referring to a specific passage in this document in explanation. A point of parliamentary inquiry needs no second, is not debatable, and is not voted upon.

Point of personal privilege

If the smoke is getting too heavy for you, the air conditioner or heater is on too high, or if there is too much noise in the room, you can ask that something be

done about it. If the matter is urgent, you may interrupt the proceedings by saying, "*Point of personal privilege*;" if the matter is not particularly urgent, you are encouraged to wait until the person speaking has finished. Such a request generally requires no second, and the chair must recognize you immediately. State the situation and ask that it be corrected. If your request seems reasonable, the chair will accommodate you.

VOTING PROCEDURES

There are several ways that votes can be taken. The most commonly used method is the *show of hands*. With rare exceptions, votes will be taken by a request from the chair to see the hands of all in favor, then all opposed, then all abstaining on each issue. The chair should ask for all three categories every time, just to be thorough, even when the majority is overwhelming.

These are only brief notes on rules of order for business meetings. For further information, see *Robert's Rules of Order--Newly Revised*.

MOTION TABLE

TYPE OF MOTION	PURPOSE	INTERRUPT	SECOND	DEBATABLE	VOTE
Adjourn	To end the committee meeting.	No	Yes	No	Simple
Amend	To change part of the language in a main motion.	No	Yes	Yes	Simple
Amend by substitution	To alter a main motion by completely rewriting it, while preserving its intent.	No	Yes	Yes	Simple
Appeal ruling of chair	To challenge a decision the chair has made about the rules of order.	Yes	Yes	Yes	Simple
Information, point of	To be allowed to ask a question about a motion being discussed, <i>not</i> to offer information.	Yes	No	No	None
Main motion	An idea a committee member wants the committee to put into practice.	No	Yes	Yes	Varies
Order of the day	To make the committee return to its agenda if it gets onto another track.	Yes	No	No	None
Order, point of	To request clarification of rules of order when it appears they are being broken.	Yes	No	No	None
Parliamentary inquiry	To ask the chair about how to do something according to rules of order.	Yes	No	No	None
Previous question	To stop debate and vote right now on whatever motion is at hand.	No	Yes	No	Two-thirds
Privilege, personal	To make a personal request of the chair or the committee.	If urgent	No	No	None
Reconsider	To reopen for debate a motion previously passed.	No	Yes	Yes	Simple
Refer, commit	To halt debate, send motion to subcommittee or ad hoc committee before vote.	No	Yes	Yes	Simple
Remove from the table	To resume consideration of a motion previously tabled before the time set.	No	Yes	No	Simple
Rescind, repeal	To void the effect of a motion previously passed.	No	Yes	Yes	Two-thirds
Table	To put off further consideration of a motion until a later date and time.	No	Yes	No	Simple
Withdraw a motion	To allow a motion's maker to take back that motion after debate has begun.	Yes	No	No	Unanimous

GLOSSARY

- Additional needs, addicts with.** Additional needs arise from physical challenges such as blindness, hearing impairment, or mobility limitations imposed by use of wheelchairs. Reaching addicts with additional needs and making our meetings and other services more accessible to them is an obligation our fellowship takes very seriously at all levels of its service structure.
- Area service committee (ASC).** A committee created to provide common services for NA groups in a specific locale. Composed of GSRs, ASC officers, and subcommittee chairpersons. Usually part of a region, to which it sends RCMs.
- Assembly district.** A subdivision of a heavily populated or geographically far-flung region within which a region holds one of its multiple assemblies. Most RSCs have only one assembly for the entire region.
- Closed meetings.** NA recovery meetings that are closed to nonaddicts.
- Common needs (special interests).** A tag referring to specialized groups formed to provide additional identification for addicts with particular needs or interests in common--for example, men's or women's groups and gay or lesbian groups.
- Conference-approved literature.** See *NA-approved literature*.
- Cooperative council (co-op).** Usually in rural settings, an arrangement whereby a number of groups in nearby towns agree to cooperatively maintain certain services affecting them but not their entire ASC.
- CPC panel.** A specialized subunit of the PI subcommittee in some areas, focusing on *cooperation* with the *professional community*.
- Fellowship-approved literature.** See *NA-approved literature*.
- Group service representative (GSR).** Elected by an NA group to participate on the group's behalf in the ASC and the regional assembly.
- GSR.** See *group service representative*.
- H&I.** See *hospitals and institutions*.
- Home group.** The group an NA member calls "home." Home group membership calls for regular attendance of its recovery meetings, financial and voluntary service support, and participation in conscience-building and decision-making processes.
- Hospitals and institutions (H&I).** A field of service usually covered by one ASC subcommittee devoted to carrying the NA message primarily to correctional inmates and treatment facility patients.
- Metro committee member (MCM).** Elected by an ASC to participate on the area's behalf on the metropolitan services committee.
- Metropolitan services committee (MSC).** A committee formed to administer an array of subcommittees providing direct NA services (PI, H&I, phonelines, etc.) in a major metropolitan district on behalf of a number of ASCs.
- NA Way Magazine, The.** The NA Fellowship's quarterly journal, published in various languages.
- NA-approved literature.** Literature officially sanctioned by the Fellowship of Narcotics Anonymous as given voice by its groups through their delegates to the World Service Conference. Also referred to as "fellowship-approved literature." Formerly known as "conference-approved literature" at a time when the entire WSC voted on the approval of new NA literature.
- Open meetings.** NA recovery meetings that allow attendance by nonaddicts.
- Phoneline.** An NA telephone contact service providing means by which an addict or a general community member can get information about Narcotics Anonymous, especially NA meeting schedules. Usually administered by an ASC subcommittee.

PI. See *public information*.

Policy log. A chronological listing of ASC policy decisions made concerning various responsibilities and fields of service. Maintained by the ASC secretary.

Public information (PI). A field of service usually covered by one ASC subcommittee devoted to carrying the NA message to government and private agencies, the public media, community leaders, those in the helping professions, and the community-at-large so that addicts seeking recovery will be referred to Narcotics Anonymous.

RCM. See *regional committee member*.

Regional assembly. A gathering of GSRs and RCMs, conducted by the RSC, to discuss issues affecting NA worldwide, usually in preparation for the annual WSC meeting. The regional delegate is elected at the assembly.

Regional committee member (RCM). Elected by an ASC to participate on the area's behalf on the regional service committee.

Regional delegate. A World Service Conference participant elected by a region's GSRs and RCMs.

Regional service committee (RSC). A body that draws together the combined service experience of a number of adjoining areas for those areas' mutual support. Composed of RCMs, the regional delegate and alternate delegate, and others as needed.

Resource assignment. Rather than create RSC subcommittees to focus regional attention and gather regional experience in the various fields of service, most RSCs give their RCMs resource assignments. For example, one or two RCMs will be designated as the people responsible to provide information to and facilitate communication between area H&I subcommittees throughout the region.

RSC. See *regional service committee*.

Service bulletins. Articles, position papers, and food for thought on a variety of NA service-related topics. A number of such bulletins are available from our World Service Office.

Shared services committee. A committee created by two or more area or regional committees to fulfill one or two needs both territories have in common. In a state, province, or nation with more than one region, such a committee would interact on those regions' behalf with state, provincial, or national government, professional, religious, and civic organizations. Funded by and accountable to those who created it.

Sharing session. A nonbusiness portion of the agenda of most NA service board or committee meetings. Somewhat more informal than the rest of the meeting because of the suspension of the ordinary rules of order. Facilitates wide-ranging, open discussion on committee issues and group problems. Allows for development of group conscience necessary before spiritually sound decisions can be made in ordinary business session.

Special interests (common needs). A tag referring to specialized groups formed to provide additional identification for addicts with particular needs or interests in common--for example, men's or women's groups and gay or lesbian groups.

Trusted servant. An NA euphemism for "leader," "official," or "officer." Derived from NA's Second Tradition, in which NA leaders are characterized as "trusted servants" as opposed to governors.

Twelve Concepts for NA Service. One of three bodies of basic NA principle, the concepts apply specifically to the development, coordination, and maintenance of NA services on behalf of the groups.

Twelve Steps. One of three bodies of basic NA principle, the steps describe NA's regimen leading to personal recovery and a spiritual awakening.

Twelve Traditions. One of three bodies of basic NA principle, the traditions provide guidance for the behavior of NA groups, helping the groups maintain their independence while nurturing their unity.

World Service Conference (WSC). A deliberative body composed of regional delegates and world-level trusted servants, the WSC provides an effective voice and active conscience for the worldwide NA Fellowship.

World Service Conference Report. The full reports of the World Service Conference and its boards and committees. Formerly known as the *Fellowship Report*.

World Service Office (WSO). World Service Board headquarters (Los Angeles) and branch facilities (Canada, Europe).

WSC. See *World Service Conference*.

WSO. See *World Service Office*.

INDEX

Note: *This index is meant to complement, not duplicate, the tables of contents found at the front of this guide. For references not found in the index, see the detail table of contents beginning on page vii.*

- Additional needs, addicts with, 30, 59
- Alternate GSR, 37
- Anonymity, public, 29
- Area boundaries, 74-75
- Boundaries, ASC, 74-75
- Budget, ASC, 64-65
- Chairperson, ASC, 50
- Closed meetings, 29
- Clubhouses, meetings in, 30
- Common needs meetings, 28,59
- Conventions
 - regional, 99-100
- Elections
 - ASC, 53
 - group, 34
- Formats, recovery meetings, 30-32
- Funding
 - ASC, 64-66, 87-88
 - MSC, 84, 87-88
 - regional conventions, 99-100
 - RSC, 98
- Fundraising, 65-66
- Group service representative, 36-37, 49
- GSR, *see group service representative*
- Guidelines, ASC, 59, 60-61
- Home group, 28
- Inventory, area, 61-62
- Learning days, workshops, 69-70
- Log, policy, 50-51, 60-61
- MCM, *see metropolitan committee members*
- Meeting locations, 29-30
 - accessibility, 30
 - in clubhouses, 30
 - in members' homes, 30
 - in political party buildings, 30
 - in treatment centers, 30
 - rent, 29-30
- Meetings
 - ASC, 66-68
 - group business, 32-33
 - group recovery, 27-28
 - RSC, 93-94
- Membership, group, 28-29
- Metropolitan committee members, 49, 87
- NA-approved literature, 32
- New ASCs, 70-71
- Officers
 - ASC, 49-52
 - group, 33-37
 - RSC, 91
- Open meetings, 29
- Participants
 - ASC, 48-49
 - RSC, 90-92
- Participation, ASC, 62-64
- Policy, ASC, 60-61
- Prudent reserve, group, 38-39
- RCM, *see regional committee members*
- Regional assembly, 96-97
 - additional regional assemblies, 103
 - assembly districts, 103
- Regional committee members, 52, 87, 90-91
- Regional delegate, 91
 - alternate, 91-92
 - election, 96-97
 - election in multidistrict regions, 103
- Regional forums, 94-96
- Resource assignments, 92-93
- Rotation, 37-38, 53
- Rural NA, 68-69

Secretary

ASC, 50-51
group, 35

Six points, 26-27

Special interest meetings, 28, 59

Subcommittees

ASC, 53-60
RSC, 100-103

Surplus funds

ASC, 64-65
group, 39

Treasurer

ASC, 51-52
group, 35-36

Treatment centers, meetings in, 30

Vice chairperson, ASC, 50

Workshops, learning days, 69-70

BULLETINS, HANDBOOKS, AND OTHER SERVICE-RELATED MATERIALS
--

Fellowship Intellectual Property Trust, a handbook describing the legal framework within which NA regulates the use of its literature and trademarks. **Note:** A series of bulletins about intellectual property issues is also available from the World Service Office. Call or write and ask for a current listing.

Guide to Phonenumber Service, A

Guide to Public Information, A

Group Booklet, *The*, containing the group chapter from this guide, published as a separate booklet.

Group Starter Kit, including *The Group Booklet*, a new-group checklist, two copies of each IP in the WSO inventory, the NA White Booklet, *The NA Way Magazine*, the *Group Treasurer's Workbook*, and a WSO literature order form

Group Treasurer's Workbook

Handbook for NA Newsletters

"Hey! What's the Basket For?", a pamphlet on NA's tradition of self-support

Hospitals and Institutions and the NA Member, a pamphlet on personal involvement in NA outreach to addicts in prisons, treatment facilities, and medical care centers

Hospitals and Institutions Handbook

Internal Use of NA Intellectual Property. A simple policy for NA groups, service boards, and committees describing how we may use NA's registered logos and copyrighted recovery literature for NA purposes while maintaining the fellowship's legal protections.

It Works—How and Why, essays on NA's Twelve Steps and Twelve Traditions

Just for Today—Daily Meditations for Recovering Addicts, containing 366 daily thoughts from other NA literature, a short essay on a recovery issue, and a closing affirmation.

Narcotics Anonymous, the Basic Text of recovery

Public Information and the NA Member, a pamphlet on personal involvement in NA's public relations program, telling the community about Narcotics Anonymous so that community members can direct addicts to NA

The NA Way Magazine, NA's fellowship journal (published quarterly in various languages)

Treasurer's Handbook

Twelve Concepts for NA Service, containing the chapter on the Twelve Concepts from this guide, published as a separate booklet. Also contains a study guide not included here.

World Service Board of Trustee bulletins on a variety of topics are available from the WSO. Call or write and ask for a current listing.

All the material listed above is available from NA's World Service Office.

Just write or call us at:

WORLD SERVICE OFFICE

PO Box 9999, Van Nuys CA 91409 USA

Telephone (818) 773-9999

Fax (818) 700-0700



Twelve Traditions of Narcotics Anonymous

1. Our common welfare should come first; personal recovery depends on NA unity.
2. For our group purpose there is but one ultimate authority—a loving God as He may express Himself in our group conscience. Our leaders are but trusted servants, they do not govern.
3. The only requirement for membership is a desire to stop using.
4. Each group should be autonomous except in matters affecting other groups or NA as a whole.
5. Each group has but one primary purpose—to carry the message to the addict who still suffers.
6. An NA group ought never endorse, finance, or lend the NA name to any related facility or outside enterprise, lest problems of money, property, or prestige divert us from our primary purpose.
7. Every NA group ought to be fully self-supporting, declining outside contributions.
8. Narcotics Anonymous should remain forever nonprofessional, but our service centers may employ special workers.
9. NA, as such, ought never be organized, but we may create service boards or committees directly responsible to those they serve.
10. Narcotics Anonymous has no opinion on outside issues; hence the NA name ought never be drawn into public controversy.
11. Our public relations policy is based on attraction rather than promotion; we need always maintain personal anonymity at the level of press, radio, and films.
12. Anonymity is the spiritual foundation of all our traditions, ever reminding us to place principles before personalities.



Twelve Concepts for NA Service

1. To fulfill our fellowship's primary purpose, the NA groups have joined together to create a structure which develops, coordinates, and maintains services on behalf of NA as a whole.
2. The final responsibility and authority for NA services rests with the NA groups.
3. The NA groups delegate to the service structure the authority necessary to fulfill the responsibilities assigned to it.
4. Effective leadership is highly valued in Narcotics Anonymous. Leadership qualities should be carefully considered when selecting trusted servants.
5. For each responsibility assigned to the service structure, a single point of decision and accountability should be clearly defined.
6. Group conscience is the spiritual means by which we invite a loving God to influence our decisions.
7. All members of a service body bear substantial responsibility for that body's decisions and should be allowed to fully participate in its decision-making processes.
8. Our service structure depends on the integrity and effectiveness of our communications.
9. All elements of our service structure have the responsibility to carefully consider all viewpoints in their decision-making processes.
10. Any member of a service body can petition that body for the redress of a personal grievance, without fear of reprisal.
11. NA funds are to be used to further our primary purpose, and must be managed responsibly.
12. In keeping with the spiritual nature of Narcotics Anonymous, our structure should always be one of service, never of government.